



Carisma high wall fan
coil units

FLY / FLY-ECM
with connectivity
WiFi and Bluetooth

TECHNICAL MANUAL



TABLE OF CONTENTS

Introduction

Introduction	p. 4
--------------	------

FLY

Version and main components	p. 5
EUROVENT Certification	p. 7
Cooling emission	p. 8
Heating emission	p. 11
Water side pressure drop	p. 12
Operation limits	p. 13
Dimension, weight and water content	p. 14
Electronic wall controls	p. 16
Electric heater	p. 17

FLY-ECM

Version and main components	p. 18
EUROVENT Certification	p. 20
Cooling emission	p. 21
Heating emission	p. 24
Water side pressure drop	p. 25
Operation limits	p. 26
Dimension, weight and water content	p. 27
Electronic wall controls	p. 29
Electric heater	p. 30

Carisma FLY / FLY-ECM Controls

Controls and units MB version	p. 31
-------------------------------	-------

Controls for KNX systems

Controls for KNX systems	p. 34
--------------------------	-------

Carisma FLY / FLY-ECM Accessories

Accessories	p. 35
-------------	-------



Sabiana take part to the Eurovent program of fan coil performance certification. The official figures are published in the web site www.eurovent-certification.com. The tested performances are:

Total cooling emission at the following conditions:

• water temperature	+7 °C E.W.T.	+12 °C L.W.T.
• air temperature	+27 °C d.b.	+19 °C w.b.

Heating emission (2 pipe units) at the following conditions:

• water temperature	+45 °C E.W.T.	+40 °C L.W.T.
• air temperature	+20 °C	

Fan absorption

Sensible cooling emission at the following conditions:

• water temperature	+7 °C E.W.T.	+12 °C L.W.T.
• air temperature	+27 °C d.b.	+19 °C w.b.

Heating emission (4 pipe units) at the following conditions:

• water temperature	+65 °C E.W.T.	+55 °C L.W.T.
• air temperature	+20 °C	

Water side pressure drop

Sound power

INTRODUCTION

The Carisma FLY is not a simple high wall fan coil: it is a symphony of engineering and design, result of the passion and pride of Made in Italy.

With a wide spectrum of models and versions, it offers installation versatility suitable for every need, embodying the essence of traditional fan coil efficiency with a modern twist.

Thanks to a modern and appealing design, in the typical RAL 9003 white colour, the unit suits every ambient perfectly, both residential and hotel.

It can house inside a 2 or 3 way valve and the condensate drain pump (optional kits) without the need of any additional rear frame.

It is available in the version with asynchronous motor and in the version with electronic motor.

All the traditional control options are available: infra-red remote control, remote supervisory wall thermostat with Modbus communication protocol.

But what really distinguishes the **Carisma FLY** is the revolutionary introduction of our WiFi and BLE solutions. With our innovative "**Sabiana WiFi**" and "**Sabiana BLE**" APP, available for Android and iOS systems, you can manage your Sabiana fan coil at a distance and/or locally by using directly your smartphone.

The graphic interface has been designed to provide the best fan coil management experience, with extreme ease of use, but at the same time the maximum availability of functions and settings.



It is moreover possible to program completely the fan coil operative mode with several time bands for each day of the week in a simple and intuitive way: this allows to combine the maximum comfort with the maximum energy efficiency.

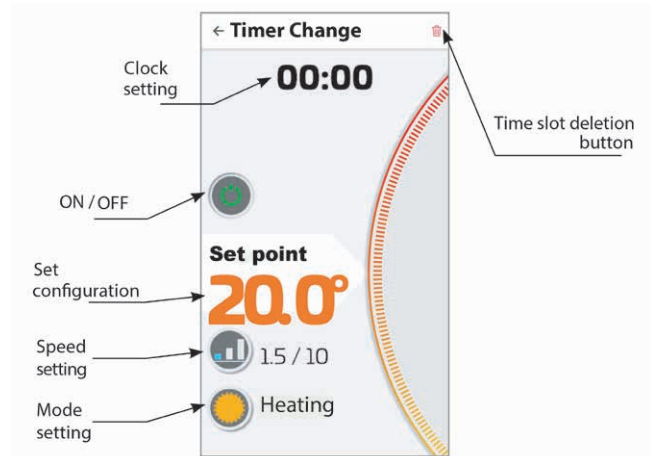

In summary:

- Elegant design suitable for fitting every ambient.
- WiFi and BLE solutions for a complete, user friendly, local and remote wireless control.
- Reduced energy consumption thanks to the use of electronic brushless motors.
- Availability in different variants to satisfy every kind of installation need.
- High quality components for an optimal and lasting performance.
- Italian production to assure the maximum quality and efficiency.

By choosing the **Carisma FLY** you decide for a high quality comfort and an unprecedented ease of control. Indeed with Sabiana the climate is always at hand.



VERSION AND MAIN COMPONENTS

Versions without electric heater

All versions are available without valves, with 2 way valve or with 3 way valve mounted in the factory.

There are four sizes available in the following versions:

CVP without infra-red remote control and without valve

CVP-2V without infra-red remote control with fitted 2 way valve

CVP-3V without infra-red remote control with fitted 3 way valve

CVP-TA with infra-red remote control and without valve

CVP-TA-2V with infra-red remote control with fitted 2 way valve

CVP-TA-3V with infra-red remote control with fitted 3 way valve

CVP-MBA with MB electronic board and without valve

CVP-MBA-2V with MB electronic board with fitted 2 way valve

CVP-MBA-3V with MB electronic board with fitted 3 way valve

Versions with electric heater

All versions are available without valves, with 2 way valve or with 3 way valve mounted in the factory.

There are four sizes available in the following versions:

CVP-E without infra-red remote control and without valve

CVP-E-2V without infra-red remote control with fitted 2 way valve

CVP-E-3V without infra-red remote control with fitted 3 way valve

CVP-TA-E with infra-red remote control and without valve

CVP-TA-E-2V with infra-red remote control with fitted 2 way valve

CVP-TA-E-3V with infra-red remote control with fitted 3 way valve

CVP-MBA-E with MB electronic board and without valve

CVP-MBA-E-2V with MB electronic board with fitted 2 way valve

CVP-MBA-E-3V with MB electronic board with fitted 3 way valve

The **CVP-TA** and **CVP-MBA** (*) units offer moreover the possibility of management via **Sabiana Wi-Fi** and "**Sabiana BLE**" APP. This makes this fan coil unit the ideal solution for the air-conditioning of every kind of ambi-ents; the **CVP-MBA** version allows the connection to a ModBus network.

The electronic board is equipped with a microprocessor with BLE / WiFi feature, that allows to control at distance or remotely all the units installed.

With the BLE / WiFi technology it is possible to manage all the fan coil operation modes.

(*) For the **MBA version** it is necessary to use the optional receiver board.

Main components

Casing

Made of auto-extinguishing ABS UL94 HB plastic with high specifications and great resistance to aging. In RAL 9003, shiny surface.

The diffusion flap is adjusted manually (not motorised flap) in CVP version, on the contrary it is adjusted by remote control in CVP-T version or with T-MB2 wall control in CVP-MB version (both with motorised flap).

Filter

Washable-regenerable synthetic filter, readily accessible.

Fan assembly

Made of plastic tangential fan.

Electric motor

The motor is wired for single phase supply and has six speeds, three of which are connected, with capacitor. The motor is fitted on sealed for life bearings and is secured on anti-vibration and self-lubricating mountings. Internal thermal protection with automatic reset, protection IP 20, class B.

The speeds connected in the factory are indicated by "MIN, MED and MAX" in the following tables.

Coil

It is manufactured from drawn copper tube and the aluminium fins are mechanically bonded onto the tube by an expansion process. The coil has two Ø 1/2 inch BSP internal connections.

The coil has Ø 1/8" inch BSP air vent and drain.

The coil is not suitable for use in corrosive atmosphere or in environments where aluminium may be subject to corrosion.

The connections are on the left side facing the unit only.

Condensate collection tray

The outside diameter of the condensate discharge pipe is Ø 16 mm.

Installation template

A cardboard installation template is supplied with every unit to help the mounting on the wall.

Electric heater

For the electric heater see p. 17



EUROVENT CERTIFICATION

2 pipe unit

The following standard rating conditions are used:

COOLING

Entering air temperature: + 27 °C d.b. + 19 °C w.b.
Water temperature: +7 °C E.W.T. +12 °C L.W.T.

HEATING

Entering air temperature: + 20 °C
Water temperature: +45 °C E.W.T. +40 °C L.W.T.



MODEL	Speed	CVP 1						CVP 2					
		1 MIN	2 MED	3	4 MAX	5	6	1 MIN	2	3 MED	4	5 MAX	6
Eurovent certified performances.		(E)	(E)	-	(E)	-	-	(E)	-	(E)	-	(E)	-
Air flow	m ³ /h	205	270	340	375	470	500	250	305	365	400	480	545
Cooling total emission (E)	kW	1,23	1,49	1,74	1,85	2,13	2,20	1,42	1,62	1,82	1,93	2,16	2,32
Cooling sensible emission (E)	kW	0,91	1,13	1,34	1,44	1,70	1,77	1,06	1,23	1,41	1,51	1,73	1,89
Heating emission (E)	kW	1,34	1,68	2,02	2,18	2,58	2,71	1,58	1,85	2,13	2,29	2,62	2,88
Dp Cooling (E)	kPa	4,8	6,8	9,0	10,1	12,9	13,8	6,2	7,9	9,8	10,8	13,2	15,1
Dp Heating (E)	kPa	4,5	6,8	9,4	10,8	14,7	15,9	6,1	8,1	10,4	11,8	15,1	17,8
Fan (E)	W	12	14	17	18	24	30	12	14	18	20	24	32
Sound power (Lw) (E)	dB(A)	35	41	46	48	52	53	39	43	47	49	53	55
Sound pressure (Lp) ⁽¹⁾	dB(A)	26	32	37	39	43	44	30	34	38	40	44	46

MODEL	Speed	CVP 3						CVP 4					
		1 MIN	2 MED	3	4 MAX	5	6	1	2 MIN	3	4 MED	5	6 MAX
Eurovent certified performances.		(E)	(E)	-	(E)	-	-	-	(E)	-	(E)	-	(E)
Air flow	m ³ /h	280	375	480	545	730	780	300	440	500	610	675	790
Cooling total emission (E)	kW	1,87	2,30	2,75	3,00	3,59	3,73	1,97	2,60	2,83	3,23	3,43	3,76
Cooling sensible emission (E)	kW	1,33	1,67	2,03	2,24	2,77	2,90	1,41	1,91	2,10	2,44	2,62	2,93
Heating emission (E)	kW	1,89	2,37	2,93	3,23	4,04	4,24	2,00	2,73	3,02	3,53	3,80	4,28
Dp Cooling (E)	kPa	11,2	16,2	22,5	26,3	36,4	39,1	14,1	23,0	27,2	34,0	38,5	45,1
Dp Heating (E)	kPa	9,1	13,8	20,1	24,1	35,9	39,2	12,7	22,2	26,7	35,2	40,4	49,8
Fan (E)	W	16	21	26	29	38	46	17	23	27	32	35	48
Sound power (Lw) (E)	dB(A)	35	40	45	51	55	57	36	43	46	51	54	57
Sound pressure (Lp) ⁽¹⁾	dB(A)	26	31	36	42	46	48	27	34	37	42	45	48

(E) Eurovent certified performance.

(1) The sound pressure levels are 9 dB (A) lower than the sound power levels, apply to the reverberant field of a 100 m³ room and a reverberation time of 0.5 sec.
MIN-MED-MAX = Speeds connected in the factory

COOLING EMISSION

Entering air temperature: 27 °C – R.H.: 50%

Model	Vn	Qv m³/h	WT: 7 / 12 °C				WT: 8 / 13 °C				WT: 10 / 15 °C				WT: 12 / 17 °C				
			Pc kW	Ps kW	Qw l/h	Dp(c) kPa	Pc kW	Ps kW	Qw l/h	Dp(c) kPa	Pc kW	Ps kW	Qw l/h	Dp(c) kPa	Pc kW	Ps kW	Qw l/h	Dp(c) kPa	
CVP 1	6	500	2,37	1,73	413	15,8	2,12	1,65	370	12,9	1,66	1,56	291	8,3	1,28	1,28	224	5,2	
	5	470	2,29	1,66	399	14,8	2,05	1,59	357	12,1	1,61	1,49	281	7,8	1,23	1,23	216	4,8	
	4	MAX	375	2,00	1,42	347	11,6	1,79	1,35	311	9,5	1,39	1,25	243	6,0	1,06	1,06	185	3,6
	3		340	1,88	1,32	326	10,3	1,68	1,25	292	8,4	1,31	1,16	228	5,3	0,99	0,99	173	3,2
	2	MED	270	1,61	1,11	279	7,8	1,44	1,05	250	6,4	1,12	0,96	194	4,0	0,84	0,84	146	2,4
	1	MIN	205	1,32	0,90	229	5,5	1,19	0,85	207	4,5	0,92	0,76	160	2,8	0,68	0,68	120	1,7
CVP 2	6	545	2,49	1,83	434	17,3	2,23	1,76	390	14,2	1,75	1,66	307	9,1	1,35	1,35	237	5,7	
	5	MAX	480	2,32	1,69	404	15,2	2,08	1,61	361	12,4	1,63	1,51	284	7,9	1,25	1,25	219	4,9
	4		400	2,08	1,49	362	12,5	1,86	1,41	324	10,2	1,45	1,31	253	6,5	1,11	1,11	194	3,9
	3	MED	365	1,97	1,39	341	11,2	1,76	1,32	306	9,1	1,37	1,22	239	5,8	1,04	1,04	182	3,5
	2		305	1,75	1,22	303	9,0	1,57	1,15	272	7,4	1,21	1,06	211	4,7	0,92	0,92	160	2,8
	1	MIN	250	1,52	1,05	264	7,1	1,37	0,99	238	5,8	1,06	0,90	184	3,6	0,79	0,79	138	2,2
CVP 3	6	780	4,01	2,86	698	44,5	3,61	2,71	629	36,6	2,83	2,53	495	23,6	2,17	2,17	381	14,6	
	5		730	3,86	2,74	671	41,4	3,47	2,59	604	34,1	2,72	2,41	475	21,9	2,08	2,08	365	13,5
	4	MAX	545	3,22	2,23	558	29,7	2,90	2,10	504	24,6	2,26	1,92	393	15,6	1,71	1,71	299	9,4
	3		480	2,95	2,02	512	25,4	2,66	1,91	463	21,1	2,07	1,73	360	13,3	1,56	1,56	273	8,0
	2	MED	375	2,46	1,66	427	18,3	2,22	1,56	386	15,2	1,73	1,40	300	9,6	1,29	1,27	225	5,7
	1	MIN	280	2,00	1,33	347	12,6	1,82	1,26	315	10,6	1,41	1,12	245	6,7	1,05	1,00	183	3,9
CVP 4	6	MAX	790	4,04	2,88	704	51,3	3,63	2,73	633	42,2	2,85	2,56	499	27,2	2,19	2,19	384	16,9
	5		675	3,69	2,60	640	43,2	3,32	2,45	576	35,7	2,59	2,27	452	22,8	1,98	1,98	346	14,0
	4	MED	610	3,46	2,42	601	38,6	3,12	2,28	542	31,9	2,44	2,10	424	20,4	1,85	1,85	324	12,4
	3		500	3,04	2,09	527	30,4	2,74	1,97	476	25,2	2,13	1,79	371	16,0	1,61	1,61	281	9,6
	2	MIN	440	2,78	1,90	482	26,0	2,51	1,79	436	21,5	1,95	1,62	340	13,6	1,47	1,47	256	8,1
	1		300	2,11	1,41	365	15,8	1,91	1,33	332	13,2	1,49	1,18	258	8,3	1,10	1,06	193	4,9

WT: Water temperature
 Vn: Nominal speeds
 Qv: Air flow
 Pc: Cooling total emission
 Ps: Cooling sensible emission
 Qw: Water flow rate
 Dp(c): Dp Cooling

Entering air temperature 26 °C – R.H.: 50%

Model	Vn	Qv m ³ /h	WT: 7 / 12 °C				WT: 8 / 13 °C				WT: 10 / 15 °C				WT: 12 / 17 °C				
			Pc kW	Ps kW	Qw l/h	Dp(c) kPa	Pc kW	Ps kW	Qw l/h	Dp(c) kPa	Pc kW	Ps kW	Qw l/h	Dp(c) kPa	Pc kW	Ps kW	Qw l/h	Dp(c) kPa	
CVP 1	6	500	2,11	1,65	368	12,9	1,88	1,60	329	10,4	1,46	1,46	256	6,6	1,11	1,11	196	4,1	
	5	470	2,04	1,58	355	12,0	1,82	1,53	316	9,7	1,41	1,41	246	6,1	1,07	1,07	188	3,8	
	4	MAX	375	1,78	1,35	310	9,4	1,58	1,30	275	7,6	1,22	1,20	213	4,7	0,92	0,92	161	2,8
	3		340	1,67	1,25	291	8,4	1,48	1,20	258	6,7	1,14	1,11	199	4,2	0,86	0,86	150	2,5
	2	MED	270	1,43	1,05	249	6,4	1,27	1,00	221	5,1	0,97	0,92	169	3,1	0,72	0,72	127	1,8
	1	MIN	205	1,18	0,85	205	4,5	1,04	0,80	182	3,6	0,79	0,73	139	2,2	0,59	0,59	103	1,3
CVP 2	6	545	2,22	1,75	387	14,1	1,98	1,70	345	11,4	1,54	1,54	270	7,3	1,18	1,18	208	4,5	
	5	MAX	480	2,07	1,61	360	12,3	1,84	1,56	320	10,0	1,43	1,43	250	6,3	1,09	1,09	191	3,9
	4		400	1,86	1,41	323	10,1	1,65	1,36	287	8,2	1,27	1,27	222	5,1	0,96	0,96	169	3,1
	3	MED	365	1,75	1,32	304	9,1	1,55	1,27	270	7,3	1,20	1,18	209	4,6	0,90	0,90	158	2,7
	2		305	1,56	1,15	270	7,4	1,38	1,10	240	5,9	1,06	1,01	184	3,6	0,79	0,79	139	2,2
	1	MIN	250	1,36	0,99	236	5,8	1,20	0,94	209	4,6	0,92	0,86	160	2,8	0,68	0,68	120	1,7
CVP 3	6	780	3,59	2,71	625	36,5	3,20	2,62	558	29,6	2,49	2,45	435	18,8	1,89	1,89	333	11,5	
	5		730	3,46	2,59	601	34,0	3,08	2,50	536	27,5	2,39	2,32	417	17,4	1,81	1,81	318	10,6
	4	MAX	545	2,88	2,10	501	24,5	2,56	2,01	446	19,7	1,97	1,84	344	12,3	1,48	1,48	259	7,3
	3		480	2,65	1,91	460	21,0	2,35	1,82	409	16,9	1,80	1,66	315	10,4	1,35	1,35	236	6,2
	2	MED	375	2,21	1,57	384	15,1	1,96	1,48	341	12,2	1,50	1,33	261	7,5	1,11	1,11	194	4,4
	1	MIN	280	1,80	1,26	313	10,5	1,61	1,18	279	8,5	1,22	1,05	213	5,2	0,90	0,90	157	3,0
CVP 4	6	MAX	790	3,62	2,73	630	42,1	3,22	2,64	562	34,1	2,51	2,47	439	21,7	1,90	1,90	336	13,2
	5		675	3,30	2,45	574	35,5	2,93	2,36	511	28,6	2,27	2,18	397	18,0	1,72	1,72	302	10,9
	4	MED	610	3,10	2,29	539	31,8	2,76	2,19	480	25,7	2,13	2,02	372	16,0	1,61	1,61	282	9,6
	3		500	2,72	1,97	473	25,1	2,42	1,88	420	20,2	1,86	1,71	324	12,5	1,39	1,39	243	7,4
	2	MIN	440	2,49	1,79	433	21,4	2,22	1,70	385	17,2	1,70	1,54	296	10,6	1,26	1,26	221	6,2
	1		300	1,90	1,33	329	13,1	1,69	1,25	293	10,6	1,28	1,12	224	6,4	0,95	0,95	166	3,7

WT: Water temperature
 Vn: Nominal speeds
 Qv: Air flow
 Pc: Cooling total emission
 Ps: Cooling sensible emission
 Qw: Water flow rate
 Dp(c): Dp Cooling

Entering air temperature: 25 °C – R.H.: 50%

Model	Vn	Qv m³/h	WT: 7 / 12 °C				WT: 8 / 13 °C				WT: 10 / 15 °C				WT: 12 / 17 °C				
			Pc kW	Ps kW	Qw l/h	Dp(c) kPa	Pc kW	Ps kW	Qw l/h	Dp(c) kPa	Pc kW	Ps kW	Qw l/h	Dp(c) kPa	Pc kW	Ps kW	Qw l/h	Dp(c) kPa	
CVP 1	6	500	1,87	1,60	328	10,4	1,66	1,55	290	8,3	1,28	1,28	225	6,9	1,06	1,06	188	3,7	
	5	470	1,81	1,53	315	9,7	1,60	1,48	279	7,8	1,23	1,23	216	6,4	1,00	1,00	177	3,4	
	4	MAX	375	1,58	1,30	274	7,6	1,39	1,25	242	6,0	1,06	1,06	186	4,9	0,81	0,81	143	2,3
	3		340	1,48	1,20	257	6,7	1,30	1,15	227	5,3	0,99	0,99	173	4,3	0,74	0,74	130	1,9
	2	MED	270	1,26	1,00	220	5,1	1,11	0,96	193	4,0	0,84	0,84	147	3,2	0,62	0,62	109	1,4
	1	MIN	205	1,04	0,81	181	3,6	0,91	0,76	159	2,8	0,69	0,69	120	2,2	0,50	0,50	89	1,0
CVP 2	6	545	1,97	1,70	345	11,4	1,75	1,65	306	9,2	1,35	1,35	238	7,7	1,13	1,13	201	4,2	
	5	MAX	480	1,83	1,55	319	9,9	1,62	1,50	283	8,0	1,25	1,25	219	6,6	1,03	1,03	181	3,5
	4		400	1,64	1,36	286	8,1	1,45	1,31	253	6,5	1,11	1,11	194	5,3	0,86	0,86	152	2,5
	3	MED	365	1,55	1,27	269	7,3	1,36	1,22	238	5,8	1,04	1,04	182	4,7	0,79	0,79	139	2,2
	2		305	1,37	1,11	239	5,9	1,21	1,06	210	4,7	0,92	0,92	160	3,8	0,68	0,68	120	1,7
	1	MIN	250	1,20	0,95	208	4,6	1,05	0,90	183	3,6	0,80	0,80	139	2,9	0,59	0,59	103	1,3
CVP 3	6	780	3,19	2,61	556	29,5	2,82	2,52	493	23,7	2,18	2,18	382	17,8	1,64	1,64	290	9,0	
	5		730	3,07	2,49	534	27,4	2,72	2,40	474	22,0	2,09	2,09	366	16,5	1,57	1,57	277	8,2
	4	MAX	545	2,55	2,01	444	19,7	2,25	1,92	392	15,7	1,72	1,72	300	11,5	1,28	1,28	225	5,6
	3		480	2,34	1,82	407	16,9	2,06	1,73	359	13,4	1,57	1,57	274	9,8	1,16	1,16	204	4,8
	2	MED	375	1,96	1,48	340	12,2	1,72	1,40	299	9,6	1,29	1,27	226	6,9	0,95	0,95	167	3,3
	1	MIN	280	1,60	1,19	277	8,4	1,40	1,12	244	6,7	1,05	1,00	183	4,8	0,77	0,77	135	2,2
CVP 4	6	MAX	790	3,21	2,64	560	34,0	2,84	2,54	497	27,3	2,19	2,19	385	20,5	1,66	1,66	293	10,4
	5		675	2,92	2,35	509	28,6	2,58	2,26	450	22,9	1,98	1,98	347	17,0	1,49	1,49	262	8,5
	4	MED	610	2,75	2,19	478	25,6	2,43	2,10	423	20,4	1,86	1,86	325	15,1	1,39	1,39	244	7,5
	3		500	2,41	1,88	419	20,2	2,12	1,79	370	16,0	1,61	1,61	282	11,7	1,20	1,20	211	5,7
	2	MIN	440	2,21	1,70	384	17,2	1,94	1,62	338	13,6	1,47	1,47	257	9,9	1,09	1,09	191	4,8
	1		300	1,68	1,26	292	10,5	1,48	1,18	257	8,3	1,11	1,06	193	5,9	0,81	0,81	142	2,8

WT: Water temperature
 Vn: Nominal speeds
 Qv: Air flow
 Pc: Cooling total emission
 Ps: Cooling sensible emission
 Qw: Water flow rate
 Dp(c): Dp Cooling

HEATING EMISSION

Entering air temperature: 20 °C

Model	Vn	Qv m ³ /h	WT: 70 / 60 °C			WT: 60 / 50 °C			WT: 50 / 40 °C			WT: 50 / 45 °C			WT: 45 / 40 °C			
			Ph kW	Qw l/h	Dp(h) kPa	Ph kW	Qw l/h	Dp(h) kPa	Ph kW	Qw l/h	Dp(h) kPa	Ph kW	Qw l/h	Dp(h) kPa	Ph kW	Qw l/h	Dp(h) kPa	
CVP 1	6	500	5,46	470	15,0	4,22	363	9,7	2,96	254	5,3	3,32	571	22,6	2,71	465	15,9	
	5	470	5,22	449	13,8	4,03	346	9,0	2,83	244	4,9	3,17	546	20,8	2,58	444	14,7	
	4	MAX	375	4,40	378	10,1	3,40	293	6,6	2,40	206	3,6	2,67	460	15,3	2,18	375	10,8
	3		340	4,07	350	8,8	3,16	271	5,8	2,23	191	3,2	2,48	426	13,3	2,02	347	9,4
	2	MED	270	3,39	292	6,4	2,63	226	4,2	1,86	160	2,3	2,06	354	9,6	1,68	289	6,8
	1	MIN	205	2,71	233	4,2	2,11	181	2,8	1,50	129	1,6	1,64	283	6,4	1,34	231	4,5
CVP 2	6	545	5,82	501	16,8	4,49	386	10,9	3,15	271	6,0	3,54	609	25,4	2,88	496	17,8	
	5	MAX	480	5,30	456	14,2	4,09	352	9,2	2,87	247	5,0	3,22	554	21,4	2,62	451	15,1
	4		400	4,62	397	11,1	3,57	307	7,2	2,52	216	4,0	2,81	483	16,7	2,29	394	11,8
	3	MED	365	4,31	370	9,8	3,33	287	6,4	2,35	202	3,5	2,62	450	14,7	2,13	367	10,4
	2		305	3,74	322	7,6	2,90	249	4,9	2,05	176	2,7	2,27	391	11,4	1,85	319	8,1
	1	MIN	250	3,19	274	5,7	2,47	213	3,7	1,75	151	2,1	1,93	333	8,5	1,58	272	6,1
CVP 3	6	780	8,54	734	36,7	6,61	569	24,0	4,68	403	13,4	5,19	893	55,5	4,24	729	39,2	
	5		730	8,13	699	33,6	6,31	542	22,0	4,46	384	12,3	4,94	850	50,8	4,04	694	35,9
	4	MAX	545	6,51	560	22,5	5,06	435	14,8	3,59	309	8,3	3,95	680	34,0	3,23	556	24,1
	3		480	5,89	507	18,8	4,58	394	12,4	3,26	280	7,0	3,57	615	28,4	2,93	503	20,1
	2	MED	375	4,78	411	12,9	3,72	320	8,5	2,66	229	4,8	2,90	498	19,4	2,37	408	13,8
	1	MIN	280	3,79	326	8,5	2,96	255	5,7	2,13	183	3,2	2,30	395	12,8	1,89	324	9,1
CVP 4	6	MAX	790	8,62	741	46,6	6,68	574	30,5	4,72	406	16,9	5,24	902	70,5	4,28	736	49,8
	5		675	7,66	659	37,7	5,95	511	24,7	4,21	362	13,8	4,66	801	57,0	3,80	654	40,3
	4	MED	610	7,11	611	32,9	5,52	475	21,6	3,92	337	12,1	4,32	743	49,7	3,53	607	35,2
	3		500	6,08	523	24,9	4,73	407	16,4	3,37	290	9,2	3,69	635	37,5	3,02	520	26,6
	2	MIN	440	5,49	472	20,7	4,28	368	13,7	3,05	262	7,7	3,34	574	31,2	2,73	469	22,2
	1		300	4,02	346	11,8	3,14	270	7,8	2,25	193	4,4	2,43	419	17,7	2,00	344	12,7

WT: Water temperature
 Vn: Nominal speeds
 Qv: Air flow
 Ph: Heating emission
 Qw: Water flow rate
 Dp(h): Dp Heating

WATER SIDE PRESSURE DROP

Coil pressure drop

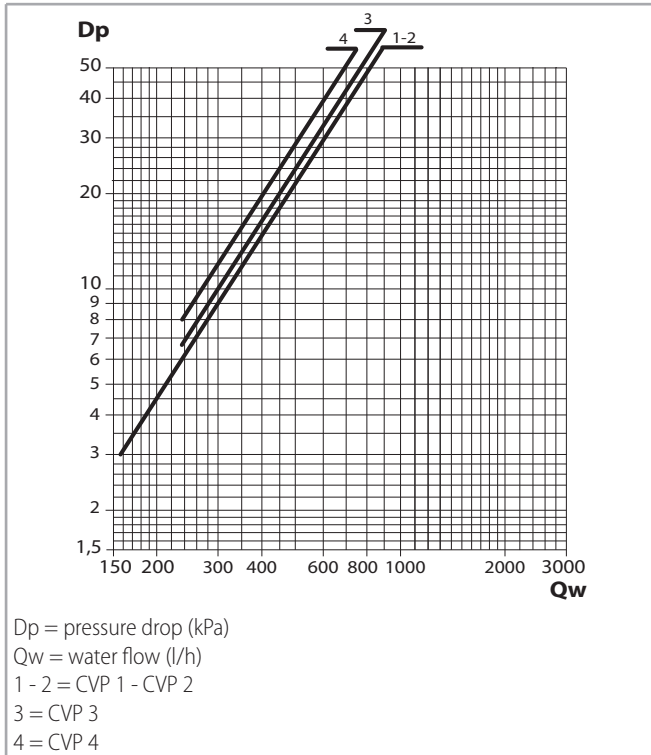

The water pressure drop figures refer to a mean water temperature of 10 °C; for different temperatures, multiply the pressure drop figures by the correction factors K.

K correction factor	Mean water temperature (°C)						
	20	30	40	50	60	70	80
	0,94	0,90	0,86	0,82	0,78	0,74	0,70

Valves pressure drop

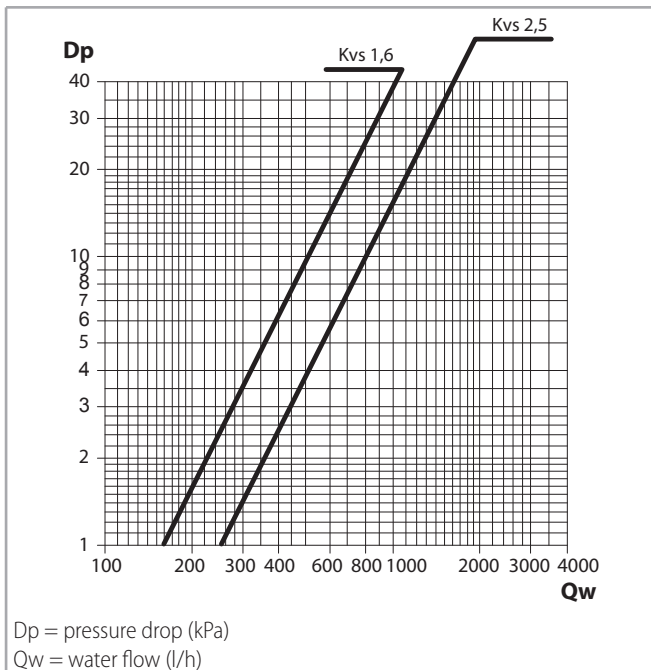

OPERATION LIMITS

Description		UoM	Value
Water flow	Coil maximum working pressure	bars	10
		kPa	1000
	Lowest water inlet temperature ⁽¹⁾	°C	+6
	Highest water inlet temperature	°C	+70
Power supply	Single-phase rated operating voltage	V/Hz	230/50

(1) for entering water temperatures below +6 °C, contact the technical department

Installation height

Model		CVP 1	CVP 2	CVP 3	CVP 4
Minimum installation height	m		2		
Maximum installation height	m		3		

Motor electrical data - max. absorption

Model		CVP 1	CVP 2	CVP 3	CVP 4
Motor absorption	W	30	32	46	48
Current absorbed	A	0,16		0,23	

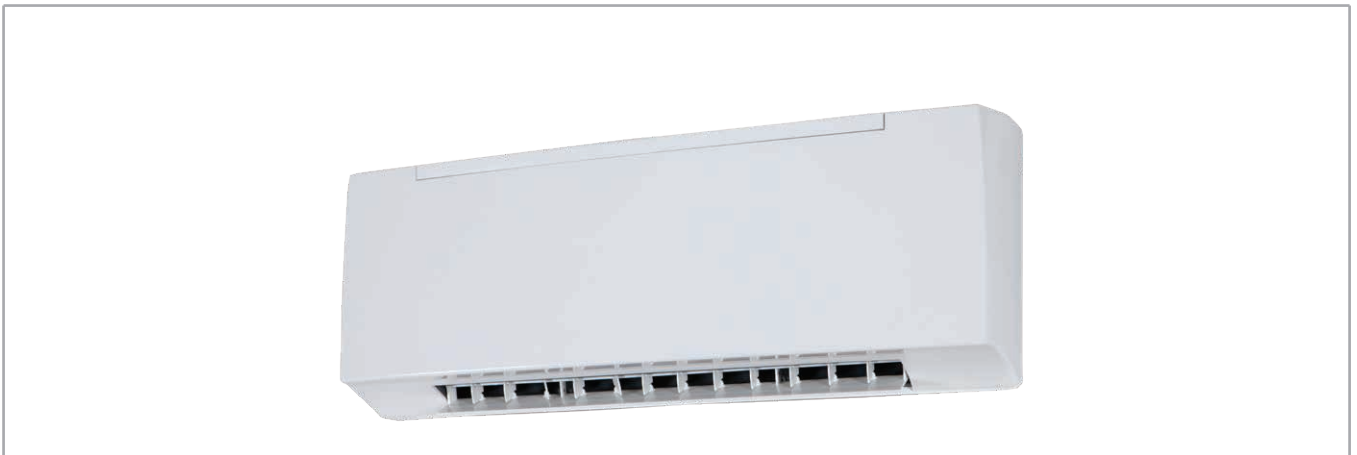
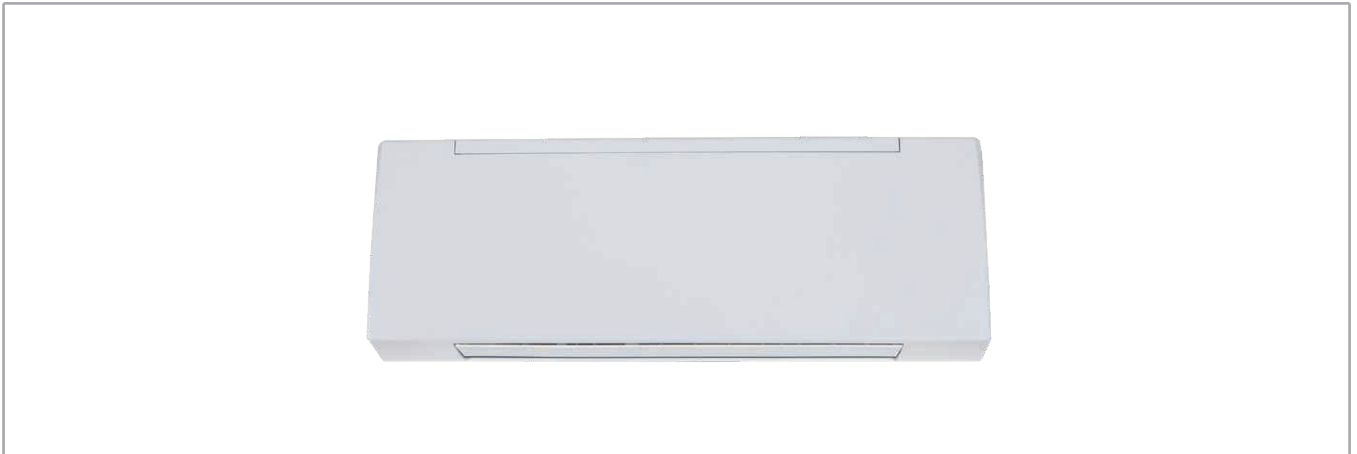

DIMENSION, WEIGHT AND WATER CONTENT

Dimensions

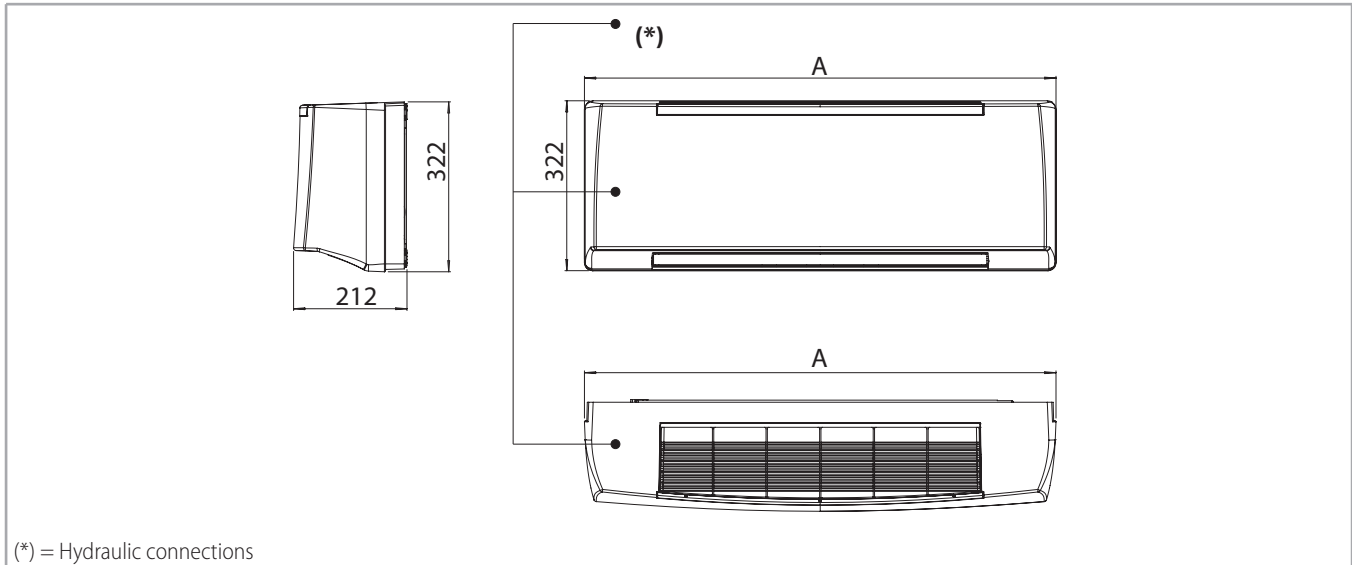

Model		CVP 1	CVP 2	CVP 3	CVP 4
A	mm	880		1185	

Fixing dimensions

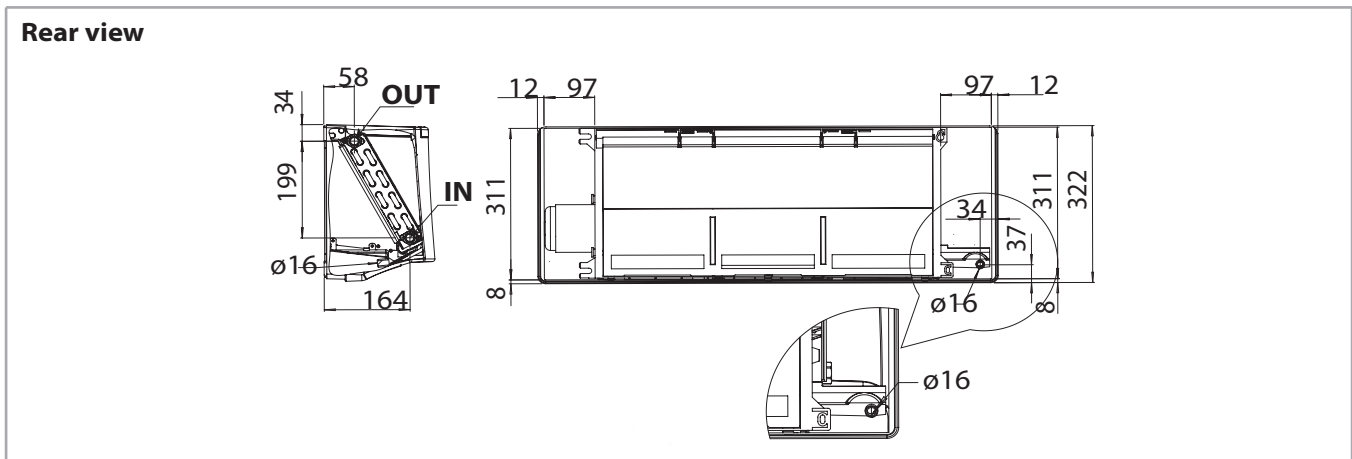
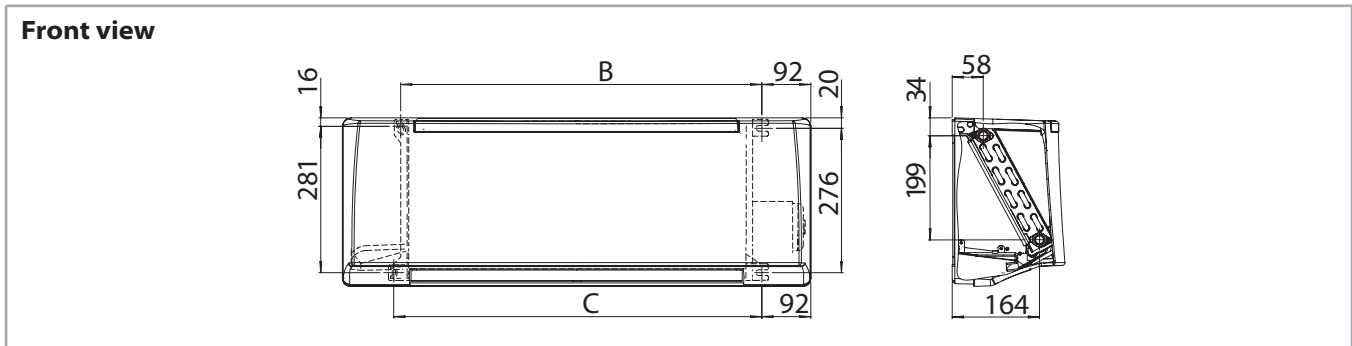

Model		CVP 1	CVP 2	CVP 3	CVP 4
B	mm	678		983	
C	mm	691		996	

Packed unit

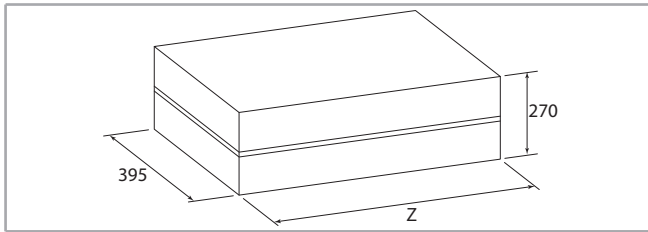

Model		CVP 1	CVP 2	CVP 3	CVP 4
Z	mm	950		1255	

Weights

Weight with packaging

Model		CVP 1	CVP 2	CVP 3	CVP 4
Weight with packaging without valves	kg	12		16	
Weight with packaging with valves	kg	13		17	

Weight without packaging

Model		CVP 1	CVP 2	CVP 3	CVP 4
Weight without packaging without valves	kg	10		13	
Weight without packaging with valves	kg	11		14	

Water content

Model		CVP 1	CVP 2	CVP 3	CVP 4
Water content	l	0,9		1,3	

ELECTRONIC WALL CONTROLS

All the units of the **Carisma Fly CVP** range can be supplied with a wide range of wall controls that allows managing one single unit or several units (with the use of speed switches).

The options range from the basic **WM-3V**, only for 3-speed control, to the highly sophisticated **WM-T**,

WM-TQR and **T2T** electronic room thermostats, that regulate the room temperature precisely and are suitable when the user wants to set the fan speed.

Note: all the controls are described in detail in the "Fan Coil Control Range literature".

Controls

WM-3V control



230 V 50 Hz

WM-T control



230 V 50-60 Hz

WM-TQR control



230 V 50-60 Hz

T2T control



230 V 50-60 Hz

ELECTRIC HEATER

According to the control provided, the electrical heater can be used as an alternative or as a supplement to the hot water; in the first case controls for example like the **WM-T** can be chosen, in the second case controls for example like **WM-TQR**.

The heater is hermetically sealed and supplied inside the coil pipes and therefore can be only factory mounted.

The electric heaters of the Fly units are single phase 230 V supply.

The electric heater is fitted with a overheat protection. The unit is fitted with two safety thermostats:

- one thermostat with manual reset.
- one thermostat with automatic reset.

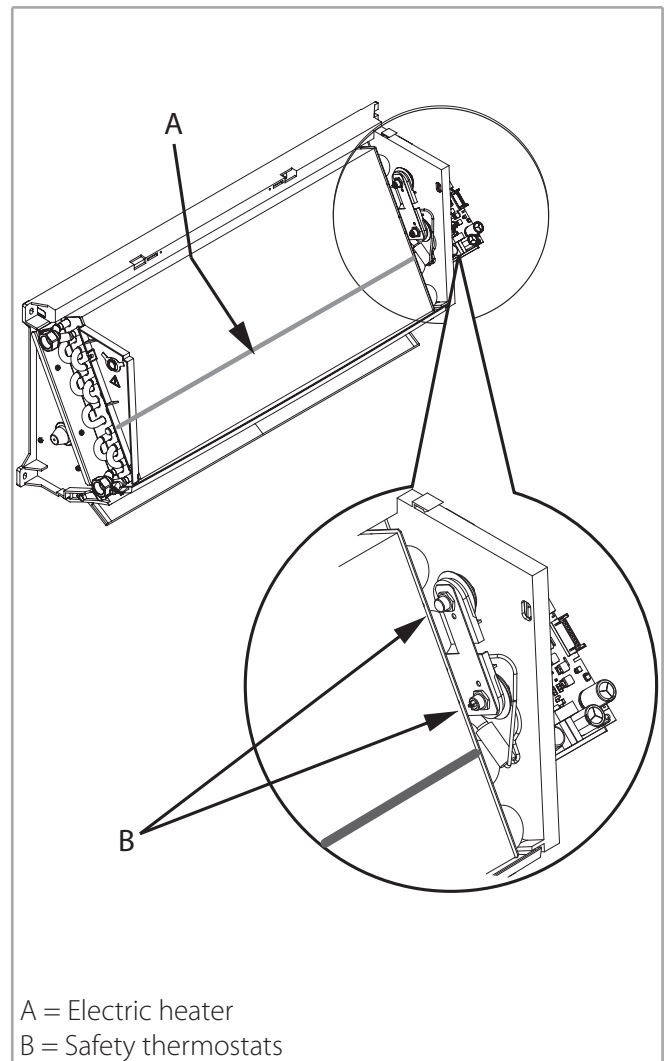

Constructional features of the main components

Model		CVP 1	CVP 2	CVP 3	CVP 4
Nominal installed power	W	1000		1500	
Maximum current absorbed	A	4,5		7,0	
Recommended fuse ⁽¹⁾	A	6 ⁽²⁾		8 ⁽²⁾	
Power supply	V/ph/Hz	230/1/50			
Connecting wires	n x mm ²	3 x 1,5			

(1) for the overload protection; gG type
(2) gG type for overload protection

Operating limits with electric heater

Max. ambient temperature for FLY with electric heater in heating mode: 25 °C.

VERSION AND MAIN COMPONENTS

Versions without electric heater

All versions are available without valves, with 2 way valve or with 3 way valve mounted in the factory.

There are five sizes available in the following versions:

CVP-ECM-A without infra-red remote control and without valve

CVP-ECM-A-2V without infra-red remote control with fitted 2 way valve

CVP-ECM-A-3V without infra-red remote control with fitted 3 way valve

CVP-ECM-TA with infra-red remote control and without valve

CVP-ECM-TA-2V with infra-red remote control with fitted 2 way valve

CVP-ECM-TA-3V with infra-red remote control with fitted 3 way valve

CVP-ECM-MBA with MB electronic board and without valve

CVP-ECM-MBA-2V with MB electronic board with fitted 2 way valve

CVP-ECM-MBA-3V with MB electronic board with fitted 3 way valve

Versions with electric heater

All versions are available without valves, with 2 way valve or with 3 way valve mounted in the factory.

Four sizes are provided (the size 0 is not available) in the following versions:

CVP-ECM-A-E without infra-red remote control and without valve

CVP-ECM-A-E-2V without infra-red remote control with fitted 2 way valve

CVP-ECM-A-E-3V without infra-red remote control with fitted 3 way valve

CVP-ECM-TA-E with infra-red remote control and without valve

CVP-ECM-TA-E-2V with infra-red remote control with fitted 2 way valve

CVP-ECM-TA-E-3V with infra-red remote control with fitted 3 way valve

CVP-ECM-MBA-E with MB electronic board and without valve

CVP-ECM-MBA-E-2V with MB electronic board with fitted 2 way valve

CVP-ECM-MBA-E-3V with MB electronic board with fitted 3 way valve

The **CVP-ECM-TA** and **CVP-ECM-MBA** (*) units offer moreover the possibility of management via "**Sabiana Wi-Fi**" and "**Sabiana BLE**" APP. This makes this fan coil unit the ideal solution for the air-conditioning of every

kind of ambients; the **CVP-ECM-MBA** version allows the connection to a ModBus network.

The electronic board is equipped with a microprocessor with BLE / WiFi feature, that allows to control at distance or remotely all the units installed.

With the BLE / WiFi technology it is possible to manage all the fan coil operation modes.

(*) For the **ECM-MBA version** it is necessary to use the optional receiver board.

Main components

Casing

Made of auto-extinguishing ABS UL94 HB plastic with high specifications and great resistance to aging. In RAL 9003, shiny surface.

The diffusion flap is adjusted manually (not motorised flap) in CVP-ECM version, on the contrary it is adjusted by remote control in CVP-ECM-T version or with T-MB2 wall control in CVP-ECM-MB version (both with motorised flap).

Filter

Washable-regenerable synthetic filter, readily accessible.

Fan assembly

Made of plastic tangential fan.

Electronic motor

Electronic motor with three phase permanent magnet brushless electronic motor that is controlled with reconstructed current according to a BLAC sinusoidal wave.

The inverter board that controls the motor operation is powered by 230 Volt, single-phase and, with a switching system, it generates a three-phase frequency modulated, wave form power supply.

The electric power supply required for the machine is therefore single-phase with voltage of 230 - 240 V and frequency of 50 - 60 Hz.

Coil

It is manufactured from drawn copper tube and the aluminium fins are mechanically bonded onto the tube by an expansion process.

The coil has two Ø 1/2 inch BSP internal connections.

The coil has Ø 1/8" inch BSP air vent and drain.

The coil is not suitable for use in corrosive atmosphere or in environments where aluminium may be subject to corrosion.

The connections are on the left side facing the unit only.

Condensate collection tray

The outside diameter of the condensate discharge pipe is \varnothing 16 mm.

Installation template

A cardboard installation template is supplied with every unit to help the mounting on the wall.

Electric heater

For the electric heater see p. 30

EUROVENT CERTIFICATION



2 pipe unit

The following standard rating conditions are used:

COOLING

Entering air temperature: + 27 °C d.b. + 19 °C w.b.
Water temperature: +7 °C E.W.T. +12 °C L.W.T.

HEATING

Entering air temperature: + 20 °C
Water temperature: +45 °C E.W.T. +40 °C L.W.T.

MODEL	Inverter power	CVP-ECM 0						CVP-ECM 1				
		1 MIN	2	3	5 MED	7,5	10 MAX	1 MIN	3	5 MED	7,5	10 MAX
Eurovent certified performances.		(E)	-	-	(E)	-	(E)	(E)	-	(E)	-	(E)
Air flow	m ³ /h	130	148	230	290	340	415	190	240	290	355	415
Cooling total emission (E)	kW	0,61	0,86	1,28	1,57	1,78	1,98	1,16	1,38	1,57	1,80	1,98
Cooling sensible emission (E)	kW	0,47	0,66	0,90	1,19	1,38	1,56	0,85	1,03	1,19	1,39	1,56
Heating emission (E)	kW	0,72	1,05	1,48	1,78	2,15	2,35	1,26	1,53	1,78	2,09	2,35
Dp Cooling (E)	kPa	1,4	2,6	5,2	7,7	9,4	11,2	5,0	5,9	7,7	9,4	11,2
Dp Heating (E)	kPa	1,6	3,0	5,6	7,5	12,0	12,4	4,0	5,7	7,5	10,0	12,4
Fan (E)	W	3	4	7	9	10	15	6	7	9	11	15
Sound power (Lw) (E)	dB(A)	26	30	38	46	49	52	35	39	46	48	52
Sound pressure (Lp) ⁽¹⁾	dB(A)	17	21	29	37	40	43	26	30	37	39	43

MODEL	Inverter power	CVP-ECM 2					CVP-ECM 3				
		1 MIN	3	5 MED	7,5	10 MAX	1 MIN	3	5 MED	7,5	10 MAX
Eurovent certified performances.		(E)	-	(E)	-	(E)	(E)	-	(E)	-	(E)
Air flow	m ³ /h	260	315	375	440	510	270	345	420	520	620
Cooling total emission (E)	kW	1,46	1,66	1,86	2,05	2,24	1,82	2,19	2,52	2,92	3,27
Cooling sensible emission (E)	kW	1,09	1,27	1,45	1,63	1,81	1,30	1,59	1,85	2,17	2,48
Heating emission (E)	kW	1,63	1,90	2,18	2,46	2,74	1,83	2,24	2,63	3,11	3,57
Dp Cooling (E)	kPa	6,9	8,2	10,1	12,0	14,1	10,7	14,8	19,0	24,8	30,4
Dp Heating (E)	kPa	6,4	8,4	10,8	13,4	16,3	8,7	12,5	16,6	22,5	28,8
Fan (E)	W	7	9	12	16	21	6	8	11	15	20
Sound power (Lw) (E)	dB(A)	40	44	47	51	55	37	42	45	49	53
Sound pressure (Lp) ⁽¹⁾	dB(A)	31	35	38	42	46	28	33	36	40	44

MODEL	Inverter power	CVP-ECM 4				
		1 MIN	3	5 MED	7,5	10 MAX
Eurovent certified performances.		(E)	-	(E)	-	(E)
Air flow	m ³ /h	375	465	550	665	770
Cooling total emission (E)	kW	2,33	2,71	3,03	3,41	3,72
Cooling sensible emission (E)	kW	1,69	2,00	2,27	2,61	2,89
Heating emission (E)	kW	2,40	2,85	3,26	3,76	4,20
Dp Cooling (E)	kPa	16,5	21,6	26,6	32,9	38,7
Dp Heating (E)	kPa	14,1	19,3	24,4	31,7	38,6
Fan (E)	W	9	12	16	22	30
Sound power (Lw) (E)	dB(A)	43	46	49	53	57
Sound pressure (Lp) ⁽¹⁾	dB(A)	34	37	40	44	48

(E) Eurovent certified performance.

(1) The sound pressure levels are 9 dB (A) lower than the sound power levels, apply to the reverberant field of a 100 m³ room and a reverberation time of 0.5 sec.

COOLING EMISSION

Entering air temperature: 27 °C – R.H.: 50%

Model	Vdc	Qv m ³ /h	WT: 7 / 12 °C				WT: 8 / 13 °C				WT: 10 / 15 °C				WT: 12 / 17 °C			
			Pc kW	Ps kW	Qw l/h	Dp(c) kPa	Pc kW	Ps kW	Qw l/h	Dp(c) kPa	Pc kW	Ps kW	Qw l/h	Dp(c) kPa	Pc kW	Ps kW	Qw l/h	Dp(c) kPa
CVP-ECM 0	10	415	2,14	1,53	370	12,9	1,91	1,46	331	10,5	1,49	1,36	259	6,7	1,14	1,14	198	4,1
	7,5	340	1,94	1,37	335	10,8	1,74	1,30	300	8,8	1,35	1,20	234	5,6	1,03	1,03	178	3,4
	5	290	1,69	1,18	293	8,5	1,52	1,11	263	7,0	1,18	1,02	204	4,4	0,89	0,89	154	2,6
	3	230	1,50	0,99	259	6,7	1,36	0,92	234	5,6	1,04	0,79	180	3,4	0,76	0,76	131	1,9
	2	148	1,07	0,70	185	3,5	0,97	0,65	167	2,7	0,76	0,57	130	1,9	0,55	0,55	95	1,1
	1	130	0,97	0,63	167	2,8	0,88	0,59	151	2,3	0,68	0,51	117	1,5	0,45	0,45	77	0,8
CVP-ECM 1	10	415	2,14	1,53	370	12,9	1,91	1,46	331	10,5	1,49	1,36	259	6,7	1,14	1,14	198	4,1
	7,5	355	1,94	1,37	335	10,8	1,74	1,30	300	8,8	1,35	1,20	234	5,6	1,03	1,03	178	3,4
	5	290	1,69	1,18	293	8,5	1,52	1,11	263	7,0	1,18	1,02	204	4,4	0,89	0,89	154	2,6
	3	240	1,49	1,02	257	6,7	1,34	0,96	231	5,5	1,03	0,88	179	3,4	0,77	0,77	134	2,0
	1	190	1,25	0,85	217	4,9	1,13	0,80	196	4,1	0,87	0,72	151	2,5	0,65	0,65	113	1,5
CVP-ECM 2	10	510	2,41	1,76	418	16,1	2,16	1,69	375	13,2	1,69	1,59	295	8,5	1,30	1,30	227	5,3
	7,5	440	2,21	1,59	383	13,8	1,98	1,52	343	11,2	1,55	1,42	269	7,2	1,18	1,18	206	4,4
	5	375	2,01	1,43	347	11,5	1,80	1,35	311	9,4	1,40	1,26	243	6,0	1,07	1,07	185	3,6
	3	315	1,79	1,26	309	9,4	1,61	1,19	278	7,7	1,25	1,09	216	4,8	0,94	0,94	164	2,9
	1	260	1,57	1,09	271	7,4	1,41	1,03	244	6,1	1,09	0,94	189	3,8	0,82	0,82	142	2,3
CVP-ECM 3	10	620	3,51	2,46	607	34,6	3,16	2,32	547	28,6	2,47	2,14	428	18,2	1,88	1,88	327	11,1
	7,5	520	3,13	2,16	541	28,1	2,83	2,04	489	23,3	2,20	1,86	381	14,8	1,67	1,67	289	8,9
	5	420	2,70	1,84	467	21,5	2,44	1,74	422	17,9	1,90	1,57	329	11,3	1,43	1,43	247	6,7
	3	345	2,35	1,58	405	16,7	2,13	1,49	367	13,9	1,65	1,34	286	8,8	1,24	1,21	214	5,2
	1	270	1,96	1,30	338	12,0	1,78	1,23	307	10,1	1,38	1,09	239	6,4	1,03	0,98	178	3,7
CVP-ECM 4	10	770	4,00	2,85	693	44,0	3,60	2,70	624	36,2	2,83	2,53	491	23,3	2,17	2,17	378	14,4
	7,5	665	3,67	2,58	634	37,5	3,30	2,43	571	30,9	2,58	2,26	448	19,8	1,97	1,97	343	12,1
	5	550	3,25	2,25	562	30,1	2,93	2,12	507	24,9	2,29	1,95	396	15,8	1,73	1,73	301	9,6
	3	465	2,90	1,99	501	24,5	2,62	1,87	453	20,3	2,04	1,70	353	12,8	1,54	1,54	267	7,7
	1	375	2,50	1,69	431	18,7	2,26	1,59	390	15,5	1,75	1,43	303	9,8	1,32	1,30	228	5,8

WT: Water temperature
Vdc: Inverter power
Qv: Air flow
Pc: Cooling total emission
Ps: Cooling sensible emission
Qw: Water flow rate
Dp(c): Dp Cooling

Entering air temperature 26 °C – R.H.: 50%

Model	Vdc	WT: 7 / 12 °C					WT: 8 / 13 °C				WT: 10 / 15 °C				WT: 12 / 17 °C			
		Qv m³/h	Pc kW	Ps kW	Qw l/h	Dp(c) kPa	Pc kW	Ps kW	Qw l/h	Dp(c) kPa	Pc kW	Ps kW	Qw l/h	Dp(c) kPa	Pc kW	Ps kW	Qw l/h	Dp(c) kPa
CVP-ECM 0	10	415	1,90	1,46	330	10,5	1,69	1,40	293	8,5	1,31	1,31	227	5,3	0,99	0,99	173	3,2
	7,5	340	1,73	1,30	299	8,8	1,53	1,25	265	7,1	1,18	1,16	205	4,4	0,89	0,89	155	2,6
	5	290	1,51	1,12	261	6,9	1,34	1,07	232	5,5	1,03	0,98	178	3,4	0,77	0,77	134	2,0
	3	230	1,30	0,90	224	4,8	1,15	0,86	198	4,2	0,85	0,75	146	2,2	0,60	0,60	103	1,2
	2	148	0,96	0,65	165	2,6	0,86	0,61	148	2,2	0,65	0,52	111	1,4	0,51	0,51	88	0,9
	1	130	0,87	0,59	149	2,3	0,78	0,55	133	1,9	0,58	0,47	100	1,1	0,46	0,46	80	0,8
CVP-ECM 1	10	415	1,90	1,46	330	10,5	1,69	1,40	293	8,5	1,31	1,31	227	5,3	0,99	0,99	173	3,2
	7,5	355	1,73	1,30	299	8,8	1,53	1,25	265	7,1	1,18	1,16	205	4,4	0,89	0,89	155	2,6
	5	290	1,51	1,12	261	6,9	1,34	1,07	232	5,5	1,03	0,98	178	3,4	0,77	0,77	134	2,0
	3	240	1,33	0,97	230	5,5	1,17	0,92	203	4,4	0,90	0,84	155	2,7	0,67	0,67	116	1,6
	1	190	1,12	0,81	194	4,1	0,99	0,76	172	3,2	0,76	0,69	131	2,0	0,56	0,56	97	1,1
CVP-ECM 2	10	510	2,15	1,68	373	13,1	1,91	1,63	333	10,6	1,49	1,49	260	6,7	1,14	1,14	199	4,1
	7,5	440	1,97	1,52	342	11,2	1,75	1,47	304	9,0	1,36	1,36	236	5,7	1,03	1,03	180	3,5
	5	375	1,79	1,35	310	9,4	1,59	1,30	275	7,5	1,22	1,21	213	4,7	0,92	0,92	161	2,8
	3	315	1,60	1,19	276	7,6	1,42	1,14	245	6,1	1,09	1,05	188	3,8	0,82	0,82	142	2,3
	1	260	1,40	1,03	243	6,1	1,24	0,98	215	4,8	0,95	0,89	165	3,0	0,71	0,71	123	1,7
CVP-ECM 3	10	620	3,15	2,32	545	28,5	3,27	2,48	565	30,4	2,16	2,05	375	14,4	1,83	1,83	318	26,6
	7,5	520	2,81	2,04	486	23,2	2,92	2,17	504	24,8	1,92	1,78	333	11,6	1,62	1,62	282	21,4
	5	420	2,43	1,74	420	17,8	2,52	1,85	436	19,0	1,65	1,49	286	8,8	1,39	1,39	242	16,2
	3	345	2,11	1,50	365	13,8	2,19	1,59	379	14,8	1,44	1,27	248	6,8	1,21	1,19	209	12,5
	1	270	1,76	1,23	304	10,0	1,83	1,31	316	10,7	1,20	1,03	207	4,9	1,01	0,96	174	9,0
CVP-ECM 4	10	770	3,58	2,70	621	36,0	3,19	2,61	554	29,2	2,48	2,43	432	18,5	1,89	1,89	330	11,3
	7,5	665	3,28	2,44	568	30,7	2,92	2,34	506	24,8	2,26	2,17	393	15,6	1,71	1,71	298	9,4
	5	550	2,91	2,13	504	24,8	2,59	2,03	449	20,0	2,00	1,87	346	12,4	1,50	1,50	261	7,4
	3	465	2,60	1,88	450	20,2	2,32	1,79	400	16,3	1,78	1,63	308	10,0	1,33	1,33	231	5,9
	1	375	2,24	1,60	387	15,4	2,00	1,51	345	12,4	1,53	1,36	264	7,6	1,13	1,13	196	4,4

WT: Water temperature
Vdc: Inverter power
Qv: Air flow
Pc: Cooling total emission
Ps: Cooling sensible emission
Qw: Water flow rate
Dp(c): Dp Cooling

Entering air temperature: 25 °C – R.H.: 50%

Model	Vdc	WT: 7 / 12 °C					WT: 8 / 13 °C					WT: 10 / 15 °C					WT: 12 / 17 °C				
		Qv m ³ /h	Pc kW	Ps kW	Qw l/h	Dp(c) kPa	Pc kW	Ps kW	Qw l/h	Dp(c) kPa	Pc kW	Ps kW	Qw l/h	Dp(c) kPa	Pc kW	Ps kW	Qw l/h	Dp(c) kPa			
CVP-ECM 0	10	415	1,68	1,40	292	8,5	1,49	1,35	258	6,7	1,14	1,14	199	4,2	0,90	0,90	157	2,7			
	7,5	340	1,53	1,25	264	7,1	1,35	1,20	233	5,6	1,03	1,03	179	3,4	0,77	0,77	135	2,1			
	5	290	1,33	1,07	231	5,5	1,17	1,02	203	4,4	0,89	0,89	155	2,7	0,66	0,66	116	1,6			
	3	230	1,10	0,87	189	4,0	1,00	0,80	178	3,4	0,75	0,75	140	2,1	0,55	0,55	95	1,1			
	2	148	0,85	0,61	146	2,3	0,75	0,57	129	1,9	0,57	0,55	98	1,2	0,45	0,43	77	0,8			
	1	130	0,77	0,55	132	1,9	0,68	0,51	116	1,6	0,51	0,50	88	1,0	0,40	0,40	69	0,7			
CVP-ECM 1	10	415	1,68	1,40	292	8,5	1,49	1,35	258	6,7	1,14	1,14	199	4,2	0,90	0,90	157	2,7			
	7,5	355	1,53	1,25	264	7,1	1,35	1,20	233	5,6	1,03	1,03	179	3,4	0,77	0,77	135	2,1			
	5	290	1,33	1,07	231	5,5	1,17	1,02	203	4,4	0,89	0,89	155	2,7	0,66	0,66	116	1,6			
	3	240	1,17	0,92	202	4,4	1,03	0,87	178	3,4	0,78	0,78	135	2,1	0,57	0,57	100	1,2			
	1	190	0,99	0,76	171	3,2	0,87	0,72	150	2,5	0,65	0,65	113	1,5	0,48	0,48	83	0,9			
CVP-ECM 2	10	510	1,90	1,63	331	10,6	1,69	1,58	294	8,5	1,31	1,31	228	5,3	1,09	1,09	191	3,9			
	7,5	440	1,75	1,46	303	9,0	1,54	1,41	268	7,2	1,19	1,19	207	4,5	0,95	0,95	166	3,0			
	5	375	1,58	1,30	274	7,5	1,40	1,25	242	6,0	1,07	1,07	186	3,7	0,82	0,82	143	2,3			
	3	315	1,41	1,14	244	6,1	1,24	1,09	215	4,9	0,95	0,95	164	3,0	0,71	0,71	123	1,7			
	1	260	1,24	0,98	214	4,8	1,09	0,93	188	3,8	0,82	0,82	143	2,3	0,61	0,61	106	1,3			
CVP-ECM 3	10	620	2,79	2,23	483	22,9	2,46	2,13	427	18,3	1,89	1,89	328	11,3	1,42	1,42	247	6,7			
	7,5	520	2,49	1,95	430	18,6	2,19	1,86	380	14,8	1,67	1,67	290	9,0	1,25	1,25	217	5,3			
	5	420	2,15	1,65	371	14,3	1,89	1,57	328	11,3	1,43	1,42	248	6,8	1,06	1,06	185	4,0			
	3	345	1,87	1,41	323	11,1	1,65	1,34	284	8,8	1,24	1,20	215	5,3	0,91	0,91	159	3,0			
	1	270	1,57	1,16	270	8,1	1,37	1,09	237	6,4	1,03	0,97	178	3,8	0,75	0,75	131	2,1			
CVP-ECM 4	10	770	3,18	2,60	551	29,1	2,82	2,51	490	23,4	2,17	2,17	379	14,6	1,64	1,64	288	8,8			
	7,5	665	2,91	2,34	504	24,8	2,57	2,25	446	19,8	1,98	1,98	344	12,3	1,49	1,49	259	7,3			
	5	550	2,58	2,03	447	19,9	2,28	1,95	395	15,9	1,74	1,74	302	9,7	1,30	1,30	226	5,7			
	3	465	2,31	1,79	399	16,2	2,03	1,70	351	12,9	1,54	1,54	268	7,8	1,15	1,15	199	4,6			
	1	375	1,99	1,51	343	12,4	1,75	1,43	302	9,8	1,32	1,29	229	5,9	0,97	0,97	169	3,4			

WT: Water temperature
 Vdc: Inverter power
 Qv: Air flow
 Pc: Cooling total emission
 Ps: Cooling sensible emission
 Qw: Water flow rate
 Dp(c): Dp Cooling

HEATING EMISSION

Entering air temperature: 20 °C

Model	Vdc	WT: 70 / 60 °C				WT: 60 / 50 °C			WT: 50 / 40 °C			WT: 50 / 45 °C			WT: 45 / 40 °C		
		Qv m³/h	Ph kW	Qw l/h	Dp(h) kPa	Ph kW	Qw l/h	Dp(h) kPa	Ph kW	Qw l/h	Dp(h) kPa	Ph kW	Qw l/h	Dp(h) kPa	Ph kW	Qw l/h	Dp(h) kPa
CVP-ECM 0	10	415	4,75	409	11,7	3,67	316	7,6	2,58	222	4,2	2,89	497	17,6	2,35	405	12,4
	7,5	340	4,22	363	9,4	3,26	281	6,1	2,30	198	3,4	2,56	441	14,2	2,09	359	10,0
	5	290	3,59	309	7,0	2,79	240	4,6	1,97	169	2,6	2,18	375	10,6	1,78	306	7,5
	3	230	3,04	261	5,3	2,35	202	3,4	1,66	142	1,7	1,85	319	7,7	1,48	255	5,6
	2	148	2,07	178	2,7	1,60	138	1,7	1,14	98	1,0	1,26	216	4,0	1,05	181	2,8
	1	130	1,84	158	2,0	1,43	123	1,4	1,02	87	0,9	1,12	192	3,3	0,72	124	1,4
CVP-ECM 1	10	415	4,75	409	11,7	3,67	316	7,6	2,58	222	4,2	2,89	497	17,6	2,35	405	12,4
	7,5	355	4,22	363	9,4	3,26	281	6,1	2,30	198	3,4	2,56	441	14,2	2,09	359	10,0
	5	290	3,59	309	7,0	2,79	240	4,6	1,97	169	2,6	2,18	375	10,6	1,78	306	7,5
	3	240	3,08	265	5,3	2,39	206	3,5	1,70	146	2,0	1,87	322	8,1	1,53	263	5,7
	1	190	2,54	219	3,8	1,98	170	2,5	1,41	121	1,4	1,54	265	5,7	1,26	217	4,0
CVP-ECM 2	10	510	5,55	477	15,4	4,28	368	10,0	3,00	258	5,5	3,37	580	23,3	2,74	472	16,3
	7,5	440	4,97	427	12,6	3,83	330	8,2	2,70	232	4,5	3,02	519	19,1	2,46	423	13,4
	5	375	4,40	378	10,1	3,40	293	6,6	2,40	206	3,6	2,67	460	15,3	2,18	375	10,8
	3	315	3,84	330	7,9	2,97	256	5,2	2,10	181	2,9	2,33	401	12,0	1,90	327	8,4
	1	260	3,29	283	6,0	2,55	220	3,9	1,81	156	2,2	2,00	344	9,1	1,63	281	6,4
CVP-ECM 3	10	620	7,19	618	26,9	5,58	480	17,7	3,96	340	9,9	4,36	751	40,6	3,57	614	28,8
	7,5	520	6,27	539	21,1	4,87	419	13,8	3,47	298	7,8	3,81	655	31,8	3,11	536	22,5
	5	420	5,29	455	15,5	4,12	354	10,2	2,94	253	5,8	3,21	553	23,4	2,63	452	16,6
	3	345	4,51	388	11,6	3,52	303	7,7	2,52	216	4,4	2,74	471	17,5	2,24	386	12,5
	1	270	3,68	316	8,1	2,87	247	5,4	2,06	177	3,1	2,23	383	12,1	1,83	315	8,7
CVP-ECM 4	10	770	8,45	727	36,1	6,55	564	23,6	4,64	399	13,1	5,14	884	54,5	4,20	722	38,6
	7,5	665	7,58	652	29,6	5,88	506	19,4	4,17	359	10,8	4,61	792	44,7	3,76	647	31,7
	5	550	6,55	563	22,8	5,09	438	15,0	3,62	311	8,4	3,98	685	34,4	3,26	560	24,4
	3	465	5,74	494	18,0	4,47	384	11,8	3,18	274	6,7	3,49	600	27,1	2,85	491	19,3
	1	375	4,83	415	13,2	3,76	324	8,7	2,69	231	4,9	2,93	504	19,8	2,40	413	14,1

WT: Water temperature
Vdc: Inverter power
Qv: Air flow
Ph: Heating emission
Qw: Water flow rate
Dp(h): Dp Heating

WATER SIDE PRESSURE DROP

Coil pressure drop

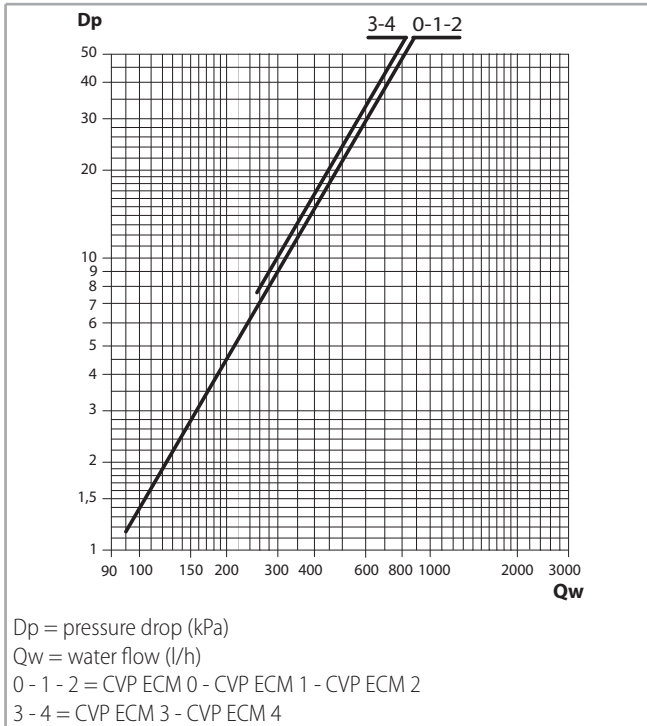

The water pressure drop figures refer to a mean water temperature of 10 °C; for different temperatures, multiply the pressure drop figures by the correction factors K.

K correction factor	Mean water temperature (°C)						
	20	30	40	50	60	70	80
	0,94	0,90	0,86	0,82	0,78	0,74	0,70

Valves pressure drop

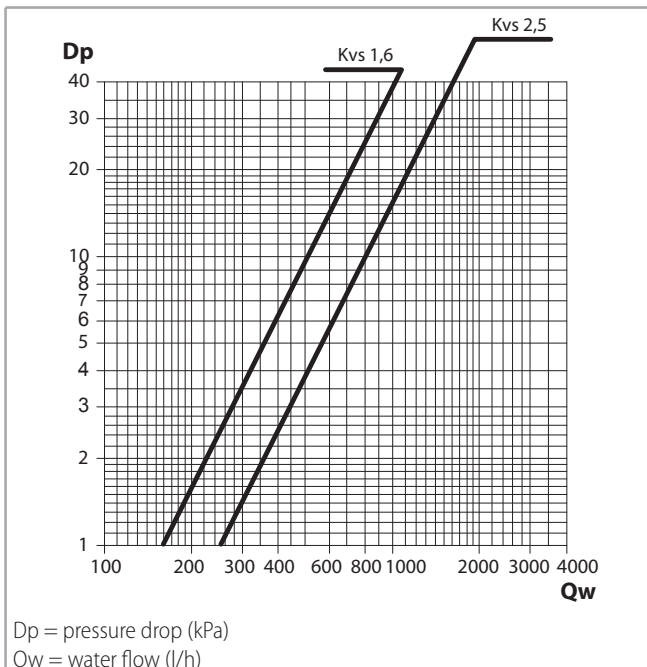

OPERATION LIMITS

Description		UoM	Value
Water flow	Coil maximum working pressure	bars	10
		kPa	1000
	Lowest water inlet temperature ⁽¹⁾	°C	+ 6 °C
	Highest water inlet temperature	°C	+ 70 °C
Power supply	Single-phase rated operating voltage	V/Hz	230/50

(1) for entering water temperatures below +6 °C, contact the technical department

Installation height

Model		CVP-ECM 0	CVP-ECM 1	CVP-ECM 2	CVP-ECM 3	CVP-ECM 4
Minimum installation height	m			2		
Maximum installation height	m			3		

Motor electrical data - max. absorption

Model		CVP-ECM 0	CVP-ECM 1	CVP-ECM 2	CVP-ECM 3	CVP-ECM 4
Motor absorption	W	15		21	20	30
Current absorbed	A	0,14		0,19	0,18	0,26

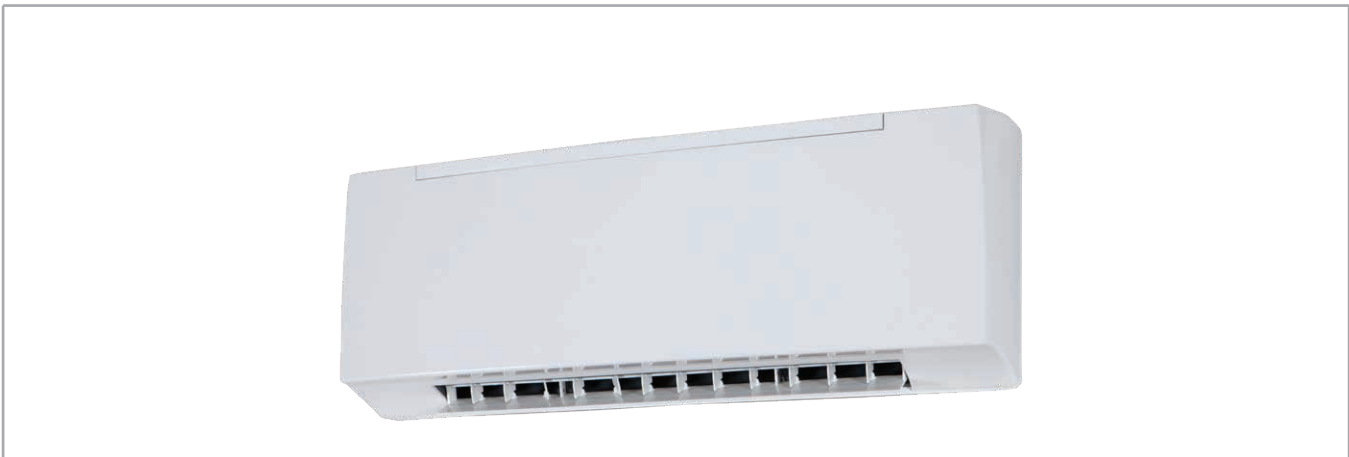
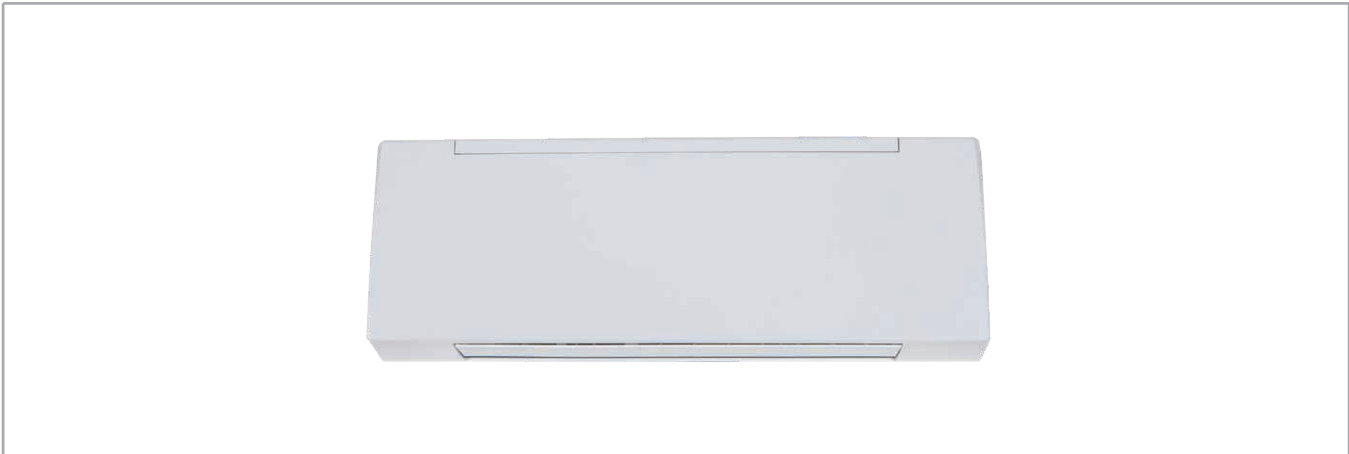

DIMENSION, WEIGHT AND WATER CONTENT

Dimensions

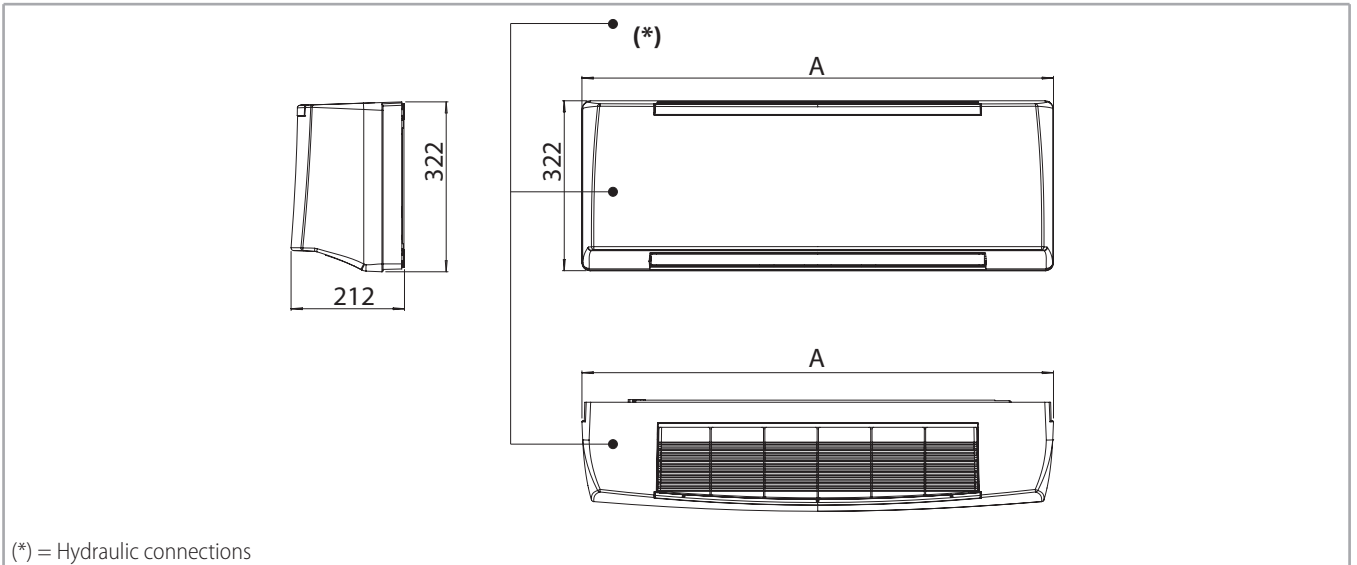

Model		CVP-ECM 0	CVP-ECM 1	CVP-ECM 2	CVP-ECM 3	CVP-ECM 4
A	mm		880			1185

Fixing dimensions

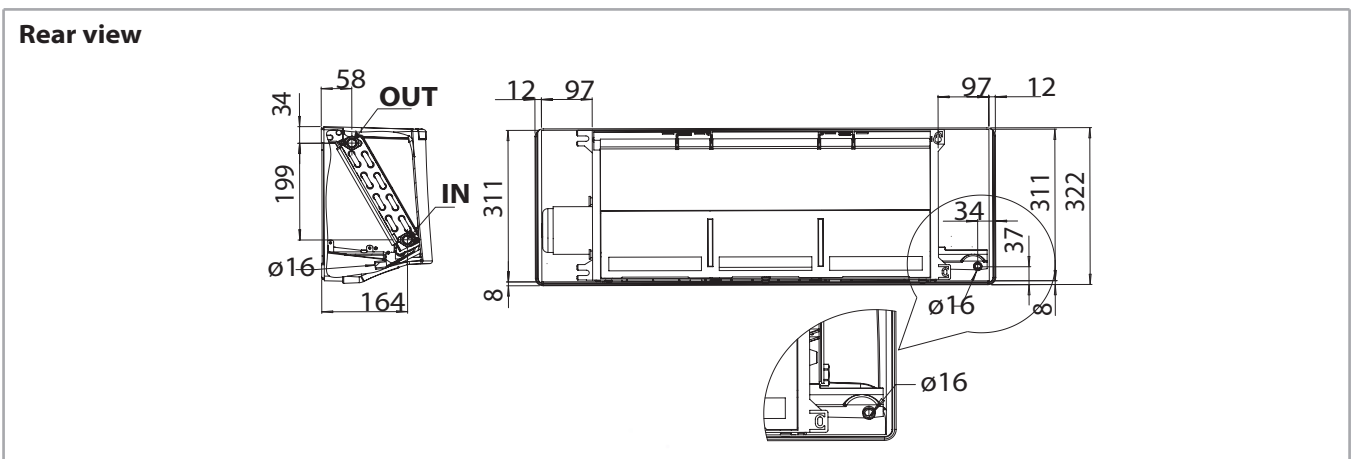
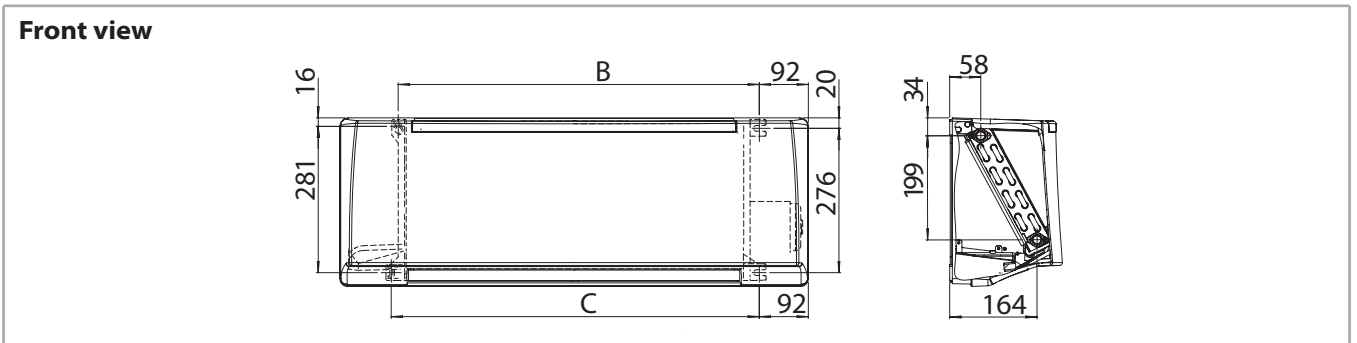

Model		CVP-ECM 0	CVP-ECM 1	CVP-ECM 2	CVP-ECM 3	CVP-ECM 4
B	mm		678			983
C	mm		691			996

Packed unit

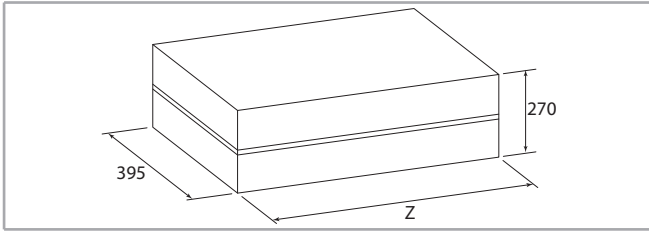

Model		CVP-ECM 0	CVP-ECM 1	CVP-ECM 2	CVP-ECM 3	CVP-ECM 4
Z	mm	950			1255	

Weights

Weight with packaging

Model		CVP-ECM 0	CVP-ECM 1	CVP-ECM 2	CVP-ECM 3	CVP-ECM 4
Weight with packaging without valves	kg	12			16	
Weight with packaging with valves	kg	13			17	

Weight without packaging

Model		CVP-ECM 0	CVP-ECM 1	CVP-ECM 2	CVP-ECM 3	CVP-ECM 4
Weight without packaging without valves	kg	10			13	
Weight without packaging with valves	kg	11			14	

Water content

Model		CVP-ECM 0	CVP-ECM 1	CVP-ECM 2	CVP-ECM 3	CVP-ECM 4
Water content	l	0,9			1,3	

ELECTRONIC WALL CONTROLS

FLY-ECM configuration

For this fan coil configuration, the 1-10 Vdc signal, which controls the inverter, must be supplied by a controller with the following signal specifications:

Fan Drive Signal

Fan OFF = 0 Vdc

Fan ON > 1 Vdc

Max. speed = 10 Vdc

ECM Blac inverter board

0÷10 Vdc Circuit Input Impedance Value = 68 kOhm

Controls

The room temperature can be controlled through the **WM-S-ECM** electronic wall thermostat, with different solutions according to every ambient conditions.

The **WM-S-ECM** electronic room thermostat regulates the room temperature precisely and is suitable when the user wants to set the fan speed manually or automatically.

Note: the control and its functions are described in detail in the "Fan Coil Control Range literature".



ELECTRIC HEATER

The heater is hermetically sealed and supplied inside the coil pipes and therefore can be only factory mounted.

The electric heaters of the FLY-ECM units are single phase 230 V supply.

The electric heater is fitted with a overheat protection. The unit is fitted with two safety thermostats:

- one thermostat with manual reset.
- one thermostat with automatic reset.

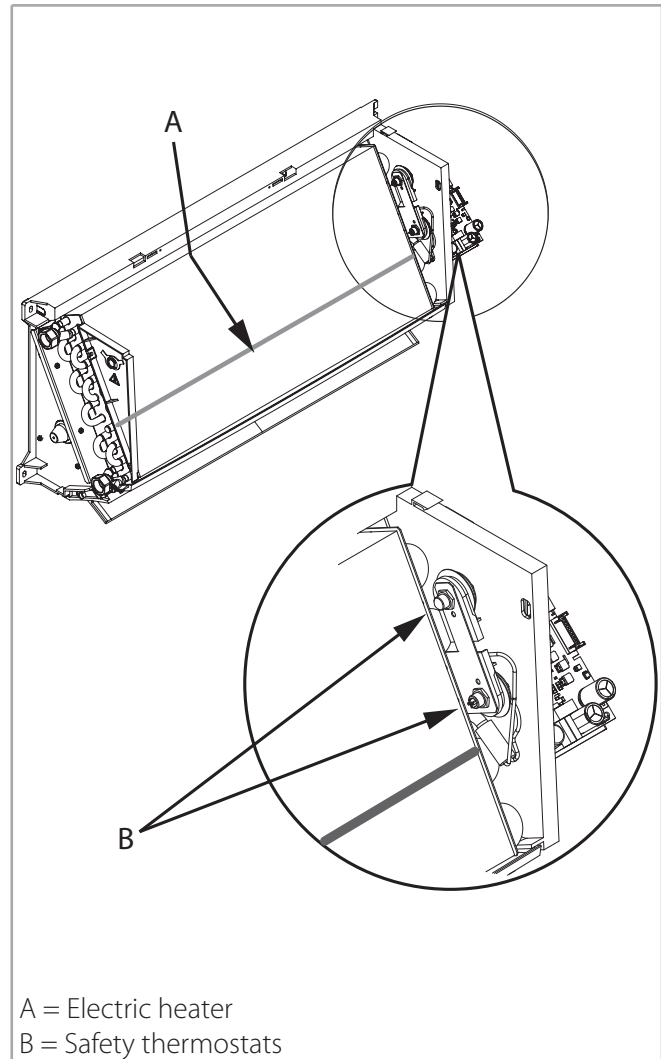

Constructional features of the main components

Model		CVP-ECM 1	CVP-ECM 2	CVP-ECM 3	CVP-ECM 4
Nominal installed power	W	1000			1500
Maximum current absorbed	A	4,5			7,0
Recommended fuse ⁽¹⁾	A	6 ⁽²⁾			8 ⁽²⁾
Power supply	V/ph/Hz	230/1/50			
Connecting wires	n x mm ²	3 x 1,5			

(1) for the overload protection; gG type
(2) gG type for overload protection

Operating limits with electric heater

Max. ambient temperature for FLY-ECM with electric coil in heating mode: 25°C.

CONTROLS AND UNITS MB VERSION

All the **CVP** and the **CVP-ECM** units can be supplied in the **TA version** and in the **MBA version**.

The **TA version** includes the infra-red remote control, that allows the management of one single unit (the basic units can not be networked); for the **TA version** it is available the "**High Wall Connectivity Kit**" cod. 9025304 (optional) Kit, that consists of an electronic board for the ModBus communication, that allows the management of one single unit or one or more groups of units by using the Modbus RTU - RS 485 communication protocol.

The **MBA version** is equipped with an auxiliary board that allows to connect the **T-MB2** wall control (optional) and with a board for the ModBus communication that allows to manage one single unit or one or more groups of units by using the Modbus RTU - RS 485 communication protocol.

Units can be managed according to the Master/Slave logic (up to 20 units) or by supervisory components.

The following devices can be connected to this system:

- The **T-MB2** wall control for the management of the single units;
- the **PSM-DI** multifunctional panel, the **Sabianet** supervisory system, the **T-DI** Touch screen multifunctional control panel and the **SabWeb** Web Gateway for Sabiana Cloud, to manage one single unit or several units.

Nota: all the controls and their features are described in detail in the "Fan Coil Control Range Literature".

All the **CVP-TA** and **CVP-MBA** units offer moreover the possibility of management via "**Sabiana WiFi**" and "**Sabiana BLE**" APP. This makes this fan coil unit the ideal solution for the air-conditioning of all residential ambients.

Warning:

- for the pairing of the units to the APP it is necessary to have the **RS-F** receiver board fitted by default on the **TA version**, optional accessory for the **MBA version**
- In case of connection of the **T-MB2** wall control (to a single unit or master/slave), the control via APP can occur only via Wi-Fi by means of pairing to **T-MB2**.

The electronic board fitted on the unit is equipped with a microprocessor with BLE / WiFi feature, that allows to control at distance or remotely all the units installed.

With the BLE / WiFi technology it is possible to manage all the fan coil operation modes.

It is moreover possible to manage each single unit or to create some groups; a weekly program can be created

by setting, for each day of the week, until four different operation modes.

Sabiana WiFi



Sabiana WiFi is the App for the control at a distance of your Sabiana system of climatization. Free and easy to use, it needs only a wireless network and a smartphone with internet connection. Using the "Cloud" it allows to manage, program and supervise the status of Your air conditioners wherever You are.

Sabiana BLE



Sabiana BLE is the new App for Android™ and iOS® systems to set, manage and control Your climatization system via Bluetooth Low Energy (BLE)® transmission. Free and easy to configure and use, it needs only a smartphone with a Bluetooth® connection (version 4.0 or later versions).

Our "**Sabiana WiFi**" and "**Sabiana BLE**" APP are compatible with iOS® e Android™ systems.

APP image

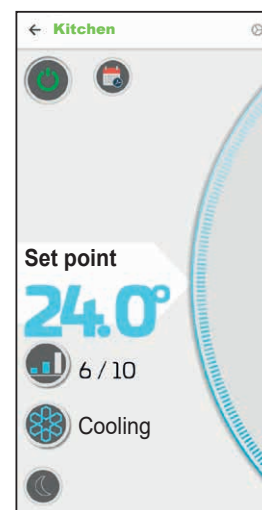
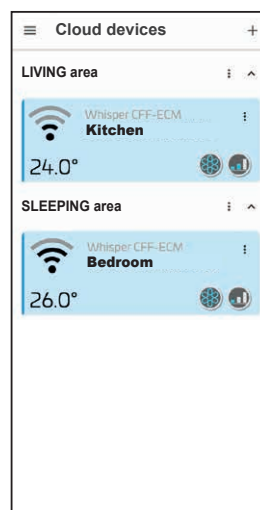

Warning: the device supports Wi-Fi networks (IEEE 802.11) of b, g and n type (Wi-Fi 4) on the 2.4 GHz frequency, according to the following security methods

- WEP
- WPA-PSK
- WPA2-PSK
- WPA2-enterprise

The device DOES NOT support Wi-Fi 6 networks on the 5 GHz frequency.

Controls

T-MB2 control



RT03 / RR03 remote control (only TA version)



High Wall Connectivity Kit (only TA version)

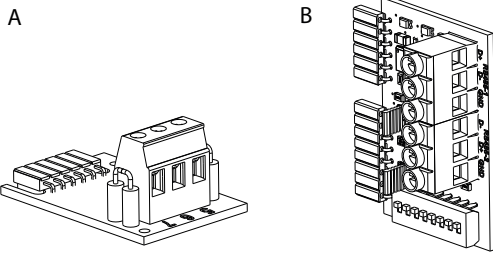

A = T-MB2 connection board
B = ModBus connection board

PC and Sabianet screenshot



T-DI Touch screen multifunction control panel

The **T-DI** multifunction control panel lets supervise and control more units with MB or SIOS boards; the panel is equipped with a 7 inches touch screen display and a serie of graphical pages that allows an easy reading of the data sent by the fan coils and the management of up to 60 units (max. 60 units: SIOS + MB).

With the **T-DI** multifunction control panel it is also possible to control the units remotely with the specific **Sabiana Cloud** for Android and iOS.

The **Sabiana Cloud** application is simple to use and lets have complete control of all the connected units.

T-DI Touch screen multifunction control panel



Web gateway for Cloud

With the Web gateway for "**Sabiana Cloud**" it is possible to control remotely up to 60 units, equipped with MB or SIOS boards (max. 60 units: SIOS + MB).

The App "**Sabiana Cloud**" is simple to use and lets have complete control of all the connected units.

SabWeb gateway for Sabiana Cloud



PSM-DI Multifunction control panel

With the **PSM-DI** multifunction control panel it is possible to control up to 60 units equipped with MB or SIOS boards (max. 60 units: SIOS + MB).

The **PSM-DI** multifunction control panel lets have complete control of all the connected units.

The remote connection (stand-alone) is not possible.

PSM-DI multifunction control panel



CONTROLS FOR KNX SYSTEMS

KNX bus system

The KNX bus system is a building automation standard for controlling, managing and monitoring a wide range of products for:

- Heating, cooling, ventilation.
- Lighting.
- Alarm systems.
- Audio and video systems.
- Electricity and gas.

Since 2016, Sabiana is a certified member of the KNX association and the certified products can be added to this system in compliance with the tests carried out at KNX laboratories.



KNX devices

The Sabiana WM-KNX room thermostat controls and adjusts the temperature of a room or area in a building. In combination with one or several UP-KNX power units, the thermostat is able to control the operation of terminal units such as fan coils.

The appliance consists of an LCD display with adjustable backlight and a sensor for measuring the room temperature.

WM-KNX is suitable for installation in a wall recessed box (to be used with UP-KNX and with PL mounting plate only).

Note: all the controls are described in detail in the "Fan Coil Control Range literature".

Recessed thermostat WM-KNX



Power unit UP-KNX



WM-KNX with rectangular plate



WM-KNX with square plate



ACCESSORIES

Connectivity kit

High Wall Connectivity Kit (only TA version)

A

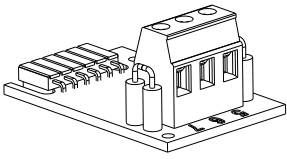

B

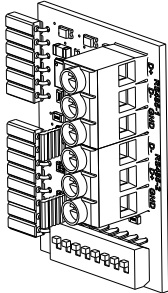

A = T-MB2 connection board
B = ModBus connection board

Model	ID	Code
0 ÷ 4	KC-F	9025304

The kit consists of two auxiliary boards to mount on the power board fitted on the unit **CVP-TA / CVP-ECM-TA**. An electronic board allows to connect the **T-MB2** wall control and the other electronic board allows to connect the unit to a ModBus. network.

FV3S 3 way valves

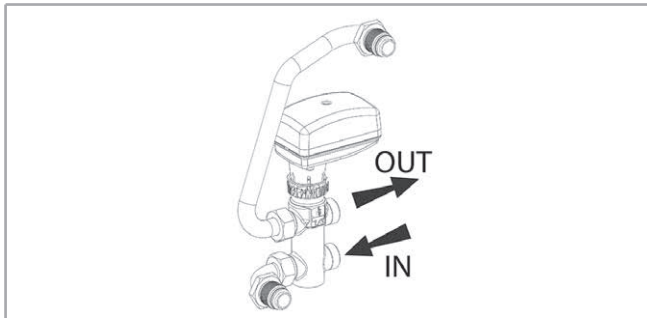

Model	Valve			Not Fitted	
	DN	(Ø)	Kvs	ID	Code
0 - 1 - 2	15	1/2"	1,6	FV3S 1-2	9025321
3 - 4	20	3/4"	2,5	FV3S 3-4	9025323

For the water side pressure drop diagrams, see at p. 12 or p. 25

FV2S 2 way valve

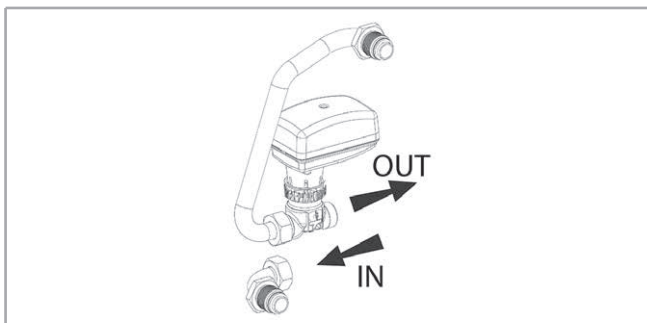

Model	Valve			Not Fitted	
	DN	(Ø)	Kvs	ID	Code
0 - 1 - 2	15	1/2"	1,6	FV2S 1-2	9025311
3 - 4	20	3/4"	2,5	FV2S 3-4	9025313

For the water side pressure drop diagrams, see at p. 12 or p. 25

PCF condensate drain pump

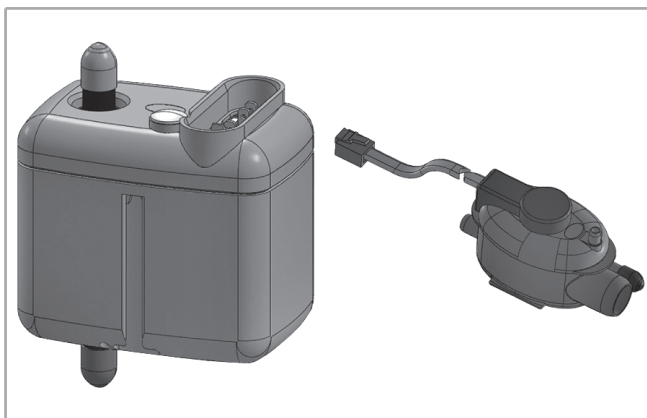

Model	FITTED		NOT FITTED	
	ID	Code	ID	Code
0 ÷ 4	PCF-M	9025319	PCF-S	9025309

Height for flow (vertical)	Water flow (l/h) depending on the length of horizontal flow	
	5 m	10 m
0		
1	7,6	7,2
2	5,6	5,2
3	4,0	3,7
4	3,2	2,9

KIF wall or concealed installation kit

Model	ID	Code
0-1-2	KIF 1-2	9025191
3-4	KIF 3-4	9025193

Wall or concealed installation kit to be used as an installation template or in case the right connections are previously designed (the units are provided only with left connections).

The technical space within the frame allows to unit the right connections of the installation and the left connections of the unit.

Two variants are available:

- Recessed box installation.
- Wall installation with aesthetic frame.

In the first case the frame is recessed, whereas in the second case it fits the unit esthetically.

The aesthetic frame characteristics are:

- Galvanized steel painted RAL 9003
- Pre-drilled panels for cables and ductworks
- Internal insulation.

Wall installation



Concealed installation



Dimensions

Sizes 0 - 1 - 2

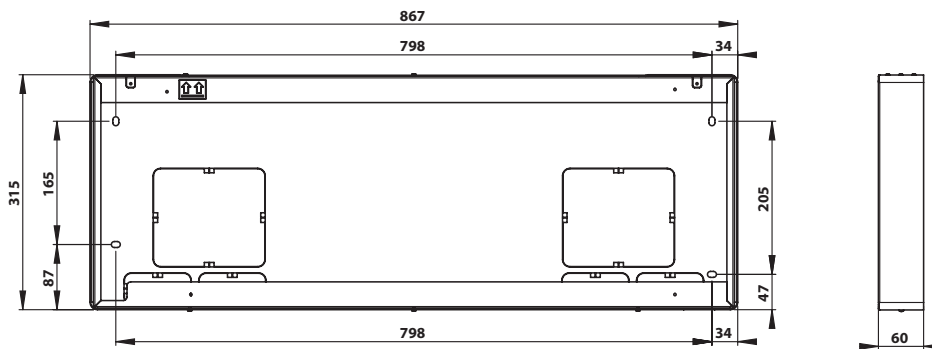

Sizes 3 - 4

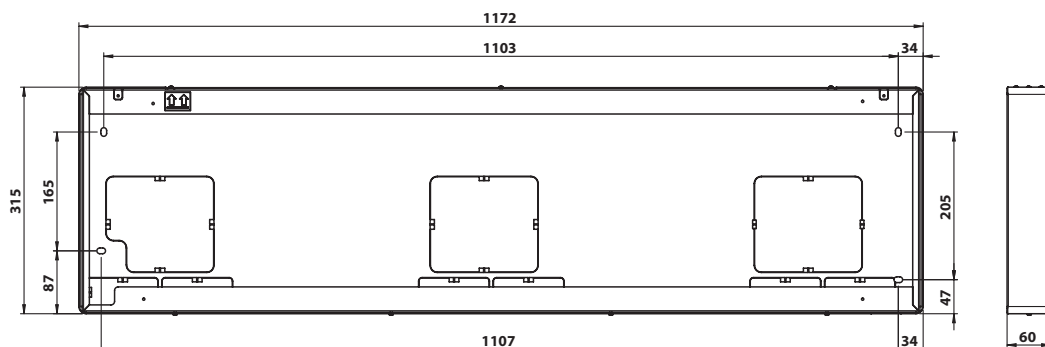

Il presente documento annulla e sostituisce il certificato di pari numero emesso in data 06/05/2022.



IQNet, the association of the world's first class certification bodies, is the largest provider of management system certification in the world. IQNet is composed of more than 30 bodies and counts over 150 subsidiaries all over the globe.

CERTIFICATO N. 0545/8
 CERTIFICATE No. _____

SI CERTIFICA CHE IL SISTEMA DI GESTIONE PER LA QUALITÀ DI
 WE HEREBY CERTIFY THAT THE QUALITY MANAGEMENT SYSTEM OPERATED BY

SABIANA S.P.A.

Sede e Unità Operativa

Via Piave, 53 - 20011 Corbetta (MI) - Italia

Processi direzionali, primari e di supporto relativamente a Progettazione, produzione e assistenza di apparecchiature per il riscaldamento e il condizionamento dell'aria (aerotermi, termostrisce radianti, ventilconvettori e unità trattamento aria) e canne fumarie.

Unità Operative

Via Virgilio, 2 - 20013 Magenta (MI) - Italia

Produzione di ventilconvettori. Magazzino Logistica.

(Presente solo reparto produttivo, magazzino componenti e logistica: Magazzino P.F. e spedizione).

Via Zanella, 27 - 20011 Corbetta (MI) - Italia

Assemblaggio unità trattamento aria, lavorazioni meccaniche, saldatura, magazzino, assemblaggio recuperatori.

È CONFORME ALLA NORMA / IS IN COMPLIANCE WITH THE STANDARD

UNI EN ISO 9001:2015

Sistema di Gestione per la Qualità / Quality Management System

PER LE SEGUENTI ATTIVITÀ / FOR THE FOLLOWING ACTIVITIES

EA: 18

Progettazione, produzione e assistenza di apparecchiature per il riscaldamento e il condizionamento dell'aria (aerotermi, termostrisce radianti, ventilconvettori e unità trattamento aria) e canne fumarie.

Design, production and service of heating and air conditioning equipment (unit heaters, radiant panels, fan coil units and air handling units) and chimneys.

Riferirsi alla documentazione del Sistema di Gestione per la Qualità aziendale per l'applicabilità dei requisiti della norma di riferimento.
 Refer to the documentation of the Quality Management System for details of application to reference standard requirements.

Il presente certificato è soggetto al rispetto del documento ICIM "Regolamento per la certificazione dei sistemi di gestione" e al relativo Schema specifico.
 The use and the validity of this certificate shall satisfy the requirements of the ICIM document "Rules for the certification of company management systems" and specific Scheme.

Per informazioni puntuali e aggiornate circa eventuali variazioni intervenute nello stato della certificazione di cui al presente certificato, si prega di contattare il n° telefonico +39 02 725341 o indirizzo e-mail info@icim.it.
 For timely and updated information about any changes in the certification status referred to in this certificate, please contact the number +39 02 725341 or email address info@icim.it.

DATA EMISSIONE
 FIRST ISSUE
 10/06/1996

EMISSIONE CORRENTE
 CURRENT ISSUE
 13/05/2022

DATA DI SCADENZA
 EXPIRING DATE
 09/04/2024

Vincenzo Delacqua
 Rappresentante Direzione / Management Representative
ICIM S.p.A.

Piazza Don Enrico Mapelli, 75 - 20099 Sesto San Giovanni (MI)
 www.icim.it

0449CM_03_IT



SGO N° 004 A



www.cisq.com

CISQ è la Federazione Italiana di Organismi di Certificazione dei sistemi di gestione aziendali.
 CISQ is the Italian Federation of management system Certification Bodies.

The descriptions and illustrations provided in this publication are not binding; **Sabiana** reserves the right, whilst maintaining the essential characteristics of the types described and illustrated, to make, at any time, without the requirement to promptly update this piece of literature, any changes that it considers useful for the purpose of improvement or for any other manufacturing or commercial requirements.



Follow us on



Sabiana app



SABIANA SpA

Società a socio unico
via Piave 53 - 20011 Corbetta (MI) Italy
T. +39 02 97203 1 r.a. - F. +39 02 9777282
info@sabiana.it
www.sabiana.it



Cert. n. 0545



Cert. n. 050153

Operative unit
via Virgilio 2, Magenta-MI Italia