



Futura FSC Fan Coil Units

The **Futura fan coil** combines innovative design with the traditional reliability and low noise of Sabiana products. The rounded shape of the cover cabinet and the white and light grey colours allow integration into all types of environments.

Available with centrifugal or tangential fans, installed in view, concealed or residential versions, the units can be controlled by numerous types of wired controllers or infrared remote controls.

As well as strict internal checks during the production processes, the main energy performance ratings are Eurovent certified.

A complete series of accessories, including the innovative Crystall electronic filter, resolves all system requirements.

The **FSC series with centrifugal fans** comes in 5 versions, 7 sizes, 14 models with single and double coil, with air flow-rates ranging from 200 to 1400 m³/h, heat outputs from 3 to 17 kW and cooling capacities from 1 to 7.5 kW.



Main components:

- **OUTER CASING**

Made from strong synthetic lateral corners and from galvanized and prepainted frontal steel sheet. The plastic top grid has fixed louvres and is reversible in order to distribute the air in two different directions.

Standard colours: - lateral corners and top grid: Pantone 427C (light grey)
- frontal sheet: RAL 9003 (white)
- other colours on request.

- **INNER CASING**

Made from galvanized steel with closed cell insulation.

- **FILTER**

The filtration medium is a washable synthetic fibre, efficiency of 73% and the filter frame is made of galvanized steel. Special plastic sliding guides allow for easy insertion and removal of the filter.

- **FAN ASSEMBLY**

The fans have aluminium blades directly keyed on the motor with double aspiration and they are dynamically and statically balanced during manufacture in order to have an extremely quiet operation.

- **ELECTRIC MOTOR**

The motor is wired for single-phase and has four speeds, three of which are connected. The motor is fitted on sealed for life bearings and is secured on antivibration and self-lubricating mountings. Protection IP 21, class B.

- **HEAT EXCHANGER**

It is manufactured from drawn copper tube and the aluminium fins are mechanically bonded onto the tube by an expansion process. The coil has two 1/2 inch BSP internal connections and 1/8 inch BSP air vent and drain. Flow and return pipe connections are situated at the same end on the left side looking at the unit. On request we can deliver the unit with the connections on the right end side. This operation can also be easily carried out on site during installation.

- **CONDENSATE COLLECTION TRAY**

Made from plastic with an "L" shape fitted on the inner casing. The outside diameter of the condensate discharge pipe is 15mm.



Certifications

2 pipe units

The following standard rating conditions are used:

COOLING

Entering air temperature +27°C d.b. +19°C w.b.
 Water temperature +7/12°C

HEATING

Entering air temperature +20°C
 Water temperature +50°C
water flow rate as for the cooling conditions

MODEL		FSC 13			FSC 23			FSC 33			FSC 43			FSC 53			FSC 63			FSC 73		
		1	2	3	1	2	3	1	2	3	1	2	3	1	2	3	1	2	3	1	2	3
Speed		1	2	3	1	2	3	1	2	3	1	2	3	1	2	3	1	2	3	1	2	3
Air flow	m ³ /h	190	240	300	290	360	450	380	480	600	480	600	750	650	800	1000	750	950	1200	850	1100	1400
Cooling total emission	kW	1,10	1,30	1,50	1,80	2,15	2,50	2,47	2,90	3,50	2,90	3,44	4,00	3,60	4,15	4,80	4,30	5,08	5,95	4,75	5,70	6,70
Cooling sensible emission	kW	0,83	1,00	1,25	1,39	1,68	2,10	1,95	2,35	2,95	2,21	2,68	3,35	2,67	3,24	4,05	3,30	4,00	5,00	3,76	4,56	5,70
Heating	kW	1,40	1,70	2,06	2,30	2,70	3,30	3,00	3,70	4,45	3,65	4,35	5,20	4,70	5,50	6,50	5,50	6,70	8,00	6,21	7,50	9,07
Δp Cooling	kPa	2,6	3,5	4,6	7,9	10,6	14,1	7,0	9,7	12,9	10,0	13,5	17,9	16,8	18,2	27,8	12,0	16,0	21,1	16,6	22,6	29,7
Δp Heating	kPa	2,1	2,9	3,8	6,5	8,6	11,4	6,0	8,2	11,0	8,2	11,0	14,5	14,1	18,1	23,4	10,4	14,1	18,4	14,6	19,7	25,8
Fan	W	20	30	50	45	50	60	60	80	95	65	80	95	65	85	125	120	145	180	135	170	210
Sound power Lw	dB(A)	40	45	50	42	47	52	35	42	51	41	47	54	44	50	58	51	56	60	54	60	65
Sound pressure Lp	dB(A)	31	36	41	33	38	43	26	33	42	32	38	45	35	41	49	42	47	51	45	51	57

MODEL		FSC 14			FSC 24			FSC 34			FSC 44			FSC 54			FSC 64			FSC 74		
		1	2	3	1	2	3	1	2	3	1	2	3	1	2	3	1	2	3	1	2	3
Speed		1	2	3	1	2	3	1	2	3	1	2	3	1	2	3	1	2	3	1	2	3
Air flow	m ³ /h	190	240	300	290	360	450	380	480	600	480	600	750	650	800	1000	750	950	1200	850	1100	1400
Cooling total emission	kW	1,30	1,50	1,80	2,00	2,40	2,80	2,70	3,30	3,90	3,20	3,90	4,60	4,20	4,80	5,70	4,60	5,50	6,60	5,20	6,30	7,50
Cooling sensible emission	kW	0,98	1,19	1,48	1,43	1,75	2,17	2,05	2,49	3,10	2,51	3,05	3,80	3,17	3,85	4,80	3,64	4,40	5,50	4,16	4,80	6,30
Heating	kW	1,60	1,95	2,30	2,50	3,00	3,50	3,20	4,00	4,80	4,00	4,80	5,80	5,20	6,20	7,40	6,00	7,30	8,80	6,70	8,30	10,1
Δp Cooling	kPa	7,0	9,8	13,1	13,1	18,0	24,7	8,7	12,4	17,0	7,4	10,0	13,6	13,3	17,6	23,4	8,0	11,0	15,0	10,1	14,4	19,6
Δp Heating	kPa	3,7	5,2	7,0	11,2	15,1	21,1	7,3	10,3	14,1	6,0	8,2	11,1	12,3	14,9	21,6	7,9	10,7	14,2	10,4	14,0	18,0
Fan	W	20	30	50	45	50	60	60	80	95	65	80	95	65	85	125	120	145	180	135	170	190
Sound power Lw	dB(A)	40	45	51	43	50	54	40	45	51	43	47	54	44	50	58	49	55	60	54	60	65
Sound pressure Lp	dB(A)	31	36	42	34	41	45	31	36	42	34	38	45	35	41	49	40	46	51	45	51	56

4 pipe units

The following standard rating conditions are used:

COOLING

Entering air temperature +27°C d.b. +19°C w.b.
 Water temperature +7/12°C

HEATING

Entering air temperature +20°C
 Water temperature +70/60°C

MODEL		FSC 13+1			FSC 23+1			FSC 33+1			FSC 43+1			FSC 53+1			FSC 63+1			FSC 73+1		
		1	2	3	1	2	3	1	2	3	1	2	3	1	2	3	1	2	3	1	2	3
Speed		1	2	3	1	2	3	1	2	3	1	2	3	1	2	3	1	2	3	1	2	3
Air flow	m ³ /h	190	240	300	290	360	450	380	480	600	480	600	750	650	800	1000	750	950	1200	850	1100	1400
Cooling total emission	kW	1,10	1,30	1,50	1,80	2,15	2,50	2,47	2,90	3,50	2,90	3,44	4,00	3,60	4,15	4,80	4,30	5,08	5,95	4,47	5,37	6,31
Cooling sensible emission	kW	0,83	1,00	1,25	1,39	1,68	2,10	1,95	2,35	2,95	2,21	2,68	3,35	2,67	3,24	4,05	3,30	4,00	5,00	3,60	4,30	5,40
Heating	kW	1,25	1,35	1,75	2,05	2,35	2,70	2,65	3,10	3,60	2,93	3,31	3,69	3,90	4,50	5,30	4,20	5,00	5,50	4,60	5,40	6,10
Δp Cooling	kPa	3,2	4,3	5,7	7,9	10,6	14,1	6,0	8,3	11,1	10,0	13,5	17,9	14,2	18,2	23,5	13,0	17,2	22,7	13,7	18,6	24,4
Δp Heating	kPa	2,2	2,8	3,7	5,3	6,7	8,6	2,4	3,2	4,3	2,3	2,9	3,7	4,7	6,9	8,8	4,7	6,2	7,6	5,9	7,7	9,6
Fan	W	20	37	49	45	50	60	60	80	95	65	80	95	60	90	130	120	145	180	135	170	190
Sound power Lw	dB(A)	40	45	51	42	50	54	35	42	51	45	48	54	48	54	59	49	55	60	55	62	66
Sound pressure Lp	dB(A)	31	36	42	33	41	45	26	33	42	36	39	45	39	45	50	40	46	51	46	53	57

The sound pressure levels apply to the reverberant field of 100m³ room and a reverberation time of 0.5 sec.



Dimensions, weight and water contents

MV Model

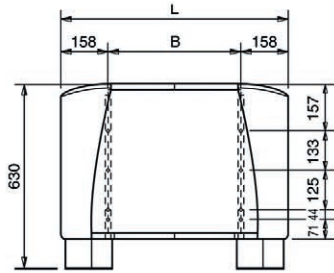

COIL CONNECTIONS

3 or 4 ROW BATTERY

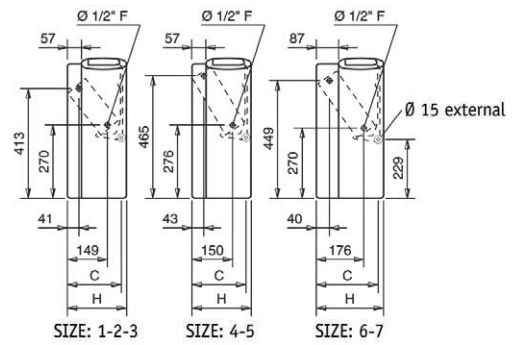

MVB-MO Model

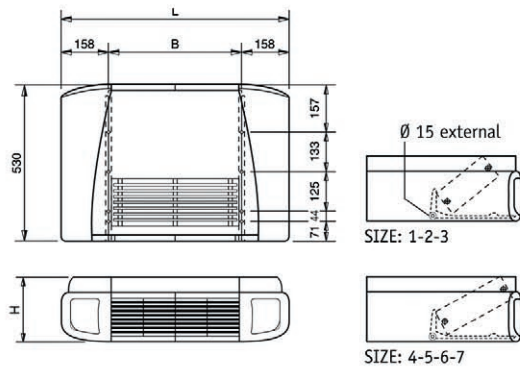

1 ROW SUPPLEMENTARY BATTERY

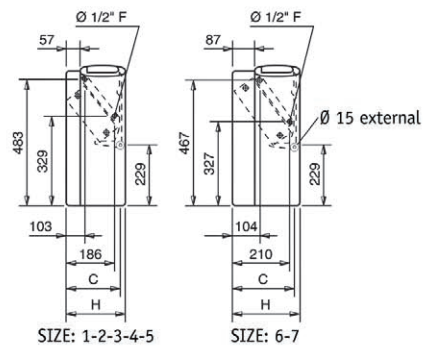

IV-IO Model

IV-IO Model horizontal installation

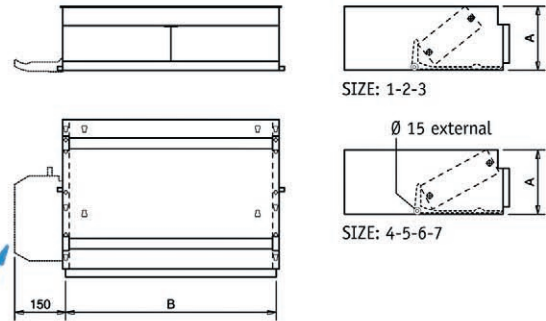
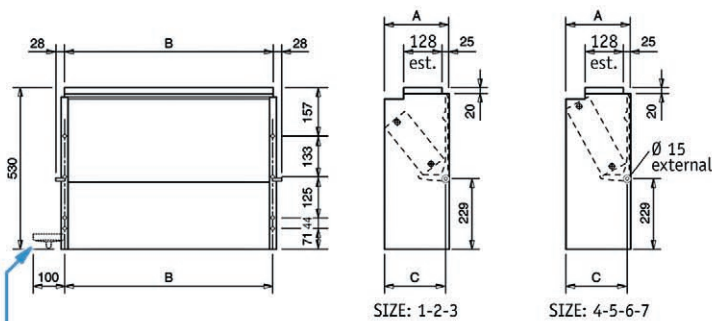

Condensate tray (Optional)

MODEL	FSC		FSC		FSC		FSC		FSC		FSC		FSC	
	13	14	23	24	33	34	43	44	53	54	63	64	73	74
WEIGHT (kg)	14	16	18	21	21	24	22	25	26	30	35	41	36	42
WATER CONTENTS (litres)	0.6	0.8	0.9	1.3	1.3	1.7	1.6	2.2	1.7	2.4	1.9	2.8	1.9	2.8
A	218		218		218		218		218		248		248	
B	454		669		884		884		1099		1099		1099	
L	770		985		1200		1200		1415		1415		1415	
H	225		225		225		225		225		255		255	
C	206		206		206		206		206		236		236	



Main controls

FITTED

REMOTE



MV - 3V

ON-OFF switch and 3 speed switch without thermostatic control.

ON-OFF switch and 3 speed switch without thermostatic control.

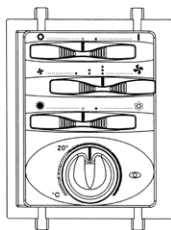
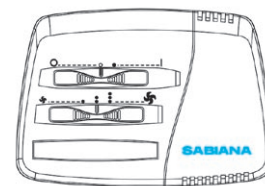

TMV - M

ON-OFF switch, 3 speed switch and summer / winter switch. Electronic room thermostat for fan control (ON-OFF).

ON-OFF switch, 3 speed switch and summer / winter switch. Electronic room thermostat for fan or valves control (ON-OFF).

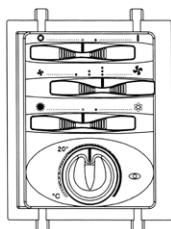
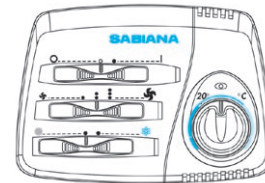

TMV - T

ON-OFF switch, 3 speed switch and summer / winter switch. Electronic room thermostat for fan or valves control (ON-OFF).

ON-OFF switch, 3 speed switch or automatic speed selection and summer / winter switch. Electronic room thermostat for fan or valves control (ON-OFF).

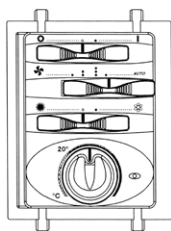
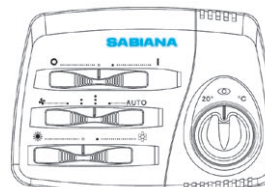

TMV - AU

ON-OFF switch, 3 speed switch or automatic speed selection and summer / winter switch. Electronic room thermostat for fan or valves control (ON-OFF).

Designed to be installed in a series 503 wall box. ON-OFF switch, 3 speed switch or automatic speed selection and summer / winter switch. Electronic room thermostat for fan or valve control (ON-OFF). This control can be used only for 2 pipe systems (with one valve only).



TMO - DI

LCD technology. ON-OFF switch, 3 speed switch or automatic speed selection and summer / winter switch. Electronic room thermostat for fan or valves control (ON-OFF).



Infra-red remote control

All the Futura fan coils can be supplied with a micro-processor managing system operated by an infra-red remote control with liquid crystall display.



PCR-DI control panel

Used to manage a series of appliances, (up to a maximum of 60) from one single control point. The PCR-DI control communicates via a serial line with all the units connected, with the possibility of controlling them all together or individually.



The complete control panel list is published on the technical catalogue.

Main accessories

- Feet
- Rear closing panel
- 2 and 3 way valve
- Inlet and outlet Flanges, Plenums and Grid (built-in models)

- Condensate collection tray
- Electric resistance
- Fresh air mixing damper
- Crystall electrostatic filter