



Air Conditioning

SABIANA

ENVIRONMENTAL COMFORT

The name Sabiana, for more than 70 years the symbol of a unit heater, is today, thanks to a wide range of products, the name of a company leader in the field of radiant heat, thermo-ventilation, air conditioning and heating, in commercial, industrial and sport buildings.

The accuracy in each manufacturing detail, and the care in quality control places Sabiana products at the highest level in Europe. Founded in 1929, Sabiana is today a company of more than 200 people organized in an area of 30.000 m² with modern machinery and processes that confirm the name Sabiana as a symbol of quality and reliability.

NOTE: Every care has been taken to ensure that the details within this brochure were accurate at the time of printing. However, we must point out that Sabiana reserves the right to amend specifications at any time without prior notice.

HORIZONTAL UNIT



SECTION WITH CRYSTALL ELECTROSTATIC FILTER AND CARBON FILTER



VERTICAL UNIT





FAN SECTION

BATTERY SECTION



Thanks to its expertise in the heating and air-conditioning field Sabiana now presents you with the Ocean series of slim-line air conditioners. They are constructed in four basic versions in order to satisfy any installation request. By the use of the same modular components 6 vertical and 9 horizontal versions can be obtained. It is also possible to mount either 2, 3, 4 or 6 row heat exchangers for water, or a 4 row heat exchanger for the direct expansion of refrigerated gases in the treatment section. The fan section can be driven directly by choosing one of the three available speeds, by a recessed remote speed control switch, or by electronic proportional speed drive. The available air volume ranges from 600 to 1400 m³/Hr on model 1, from 1000 to 2100 m³/Hr on model 2, from 1500 to 3000 m³/Hr on model 3 and from 2400 to 5300 on model 4. Thanks to its modular construction the unit can be easily disassembled and re-assembled on site and the air flow direction can be changed according to the specific needs. Additional features like condensate collection trays, humidification etc. can also be easily added later. The special construction makes the inspection and the removal of the fan assembly and heat exchangers extremely easy.

Construction features

Casing

Consists of self-supporting panels in hot dip galvanized, prepainted steel, which are completely insulated with a 20 mm. thick, thermoacoustic, flame retardant lining.

Fan section

Consists of centrifugal fans in galvanized steel with two impellers and a directly coupled single phase, three speed motor, 230/240 Volt/50 Hz with permanently installed condenser, insulation class F, power 185 W for sizes 1 and 2, 420 W for size 3 and 2 x 350 W for size 4.

Heat Exchanger

Constructed in 3/8" dia expanded copper tubes with aluminium fins with a pitch of 2,1 mm. The steel headers have an extra tapping for an air vent and 3/4" male connections for sizes 1 and 2, 1" for size 3 and 1 1/4" for size 4. The heat exchanger is mounted in a galvanized steel carrying frame.

Noise level

The average noise level is measured in the open air at a distance of one meter from the mouth of the unit.

SIZE 1		
speed	dB (A)	m ³ /h
1	45	650
2	51	1000
3	55	1400

SIZE 2		
speed	dB (A)	m ³ /h
1	50	1150
2	55	1550
3	60	2100

SIZE 3		
speed	dB (A)	m ³ /h
1	53	1750
2	56	2300
3	61	3000

SIZE 4		
speed	dB (A)	m ³ /h
1	55	2500
2	61	3800
3	65	5300

	a	b	c	d	x	z	w
SIZE 1	335	300	65	195	600	950	805
SIZE 2	415	380	40	300	760	950	805
SIZE 3	515	480	40	400	960	950	805
SIZE 4	515	480	40	400	960	1500	1355

FAN SECTION SVE

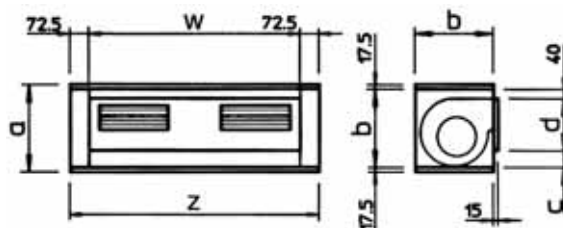

HEAT EXCHANGER SECTION SBO

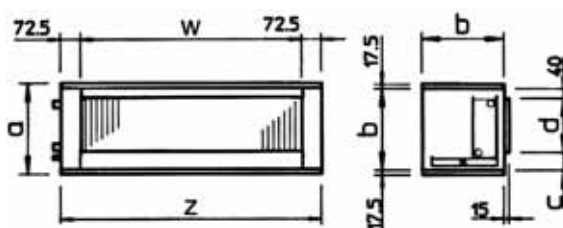

FILTER SECTION SFS

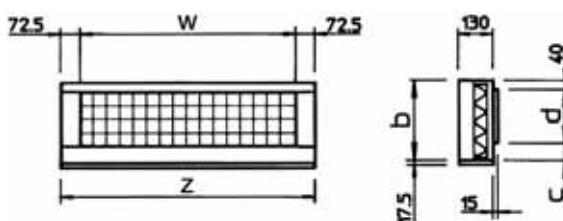

SECTION WEIGHTS Kg.					
SIZE	1	2	3	4	
FAN SECTION	23	28	32	52	
BATTERY SECTIONS	2 ROWS	14	18	22	38
	3 ROWS	16	20	24	42
	4 ROWS	18	22	26	45
	6 ROWS	22	28	34	55
	DIRECT EXPANSION	19	23	27	46

Heat exchanger
The heat exchangers are tested to a pressure of 30 Bar. In normal operation the water temperature should not exceed 95°C and the maximum working pressure 10 Bar. On request special heat exchangers can be supplied for H.T.H.W. Where a cooling battery is fitted the battery should always be fitted in a vertical position; if the unit is being used for heating only then the battery can be mounted either vertically or horizontally.

Operation limits

Electric motors

The treated air must not exceed a temperature of 55°C with 230V 50Hz supply and 50°C with 240V 50Hz supply.

Connection side in relation to the air flow direction

(It must be specified on the order)

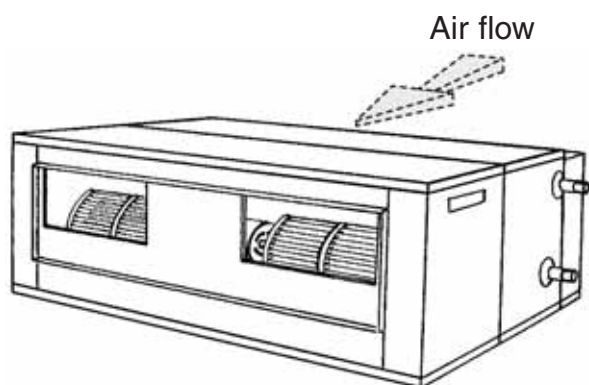

Left side connections

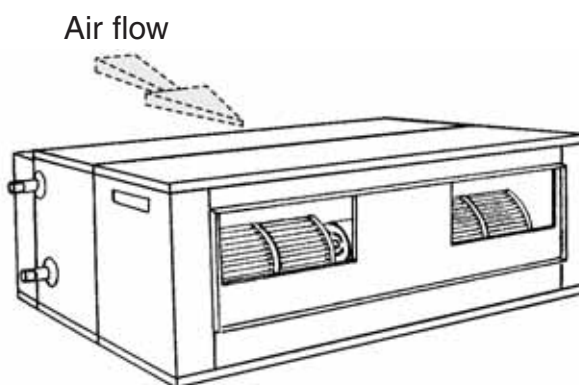

Right side connections

In addition to the 12 versions available using standard components a wide range of further combinations can be achieved and for each of them you can choose between the four different types of heat exchanger.

The sizes 1, 2, 3 of the Ocean air conditioner can be supplied with the Crystall electrostatic filter (see page 17).

Heating and cooling

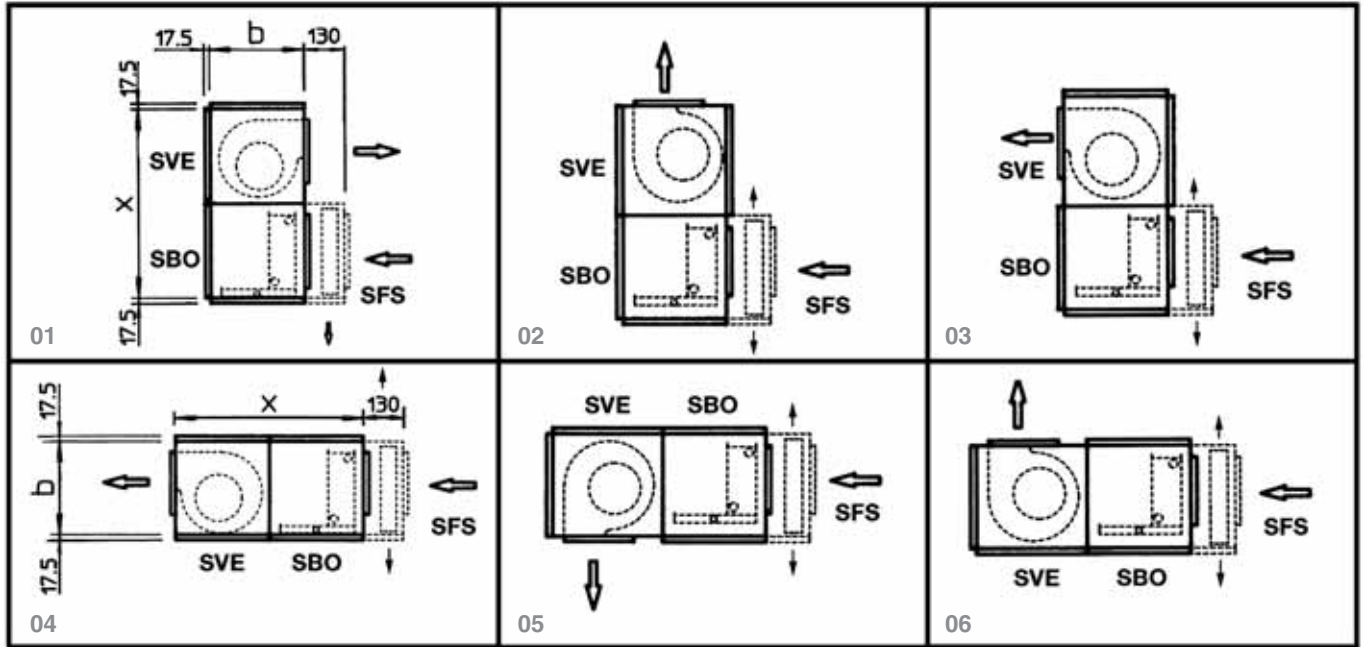

Heating only

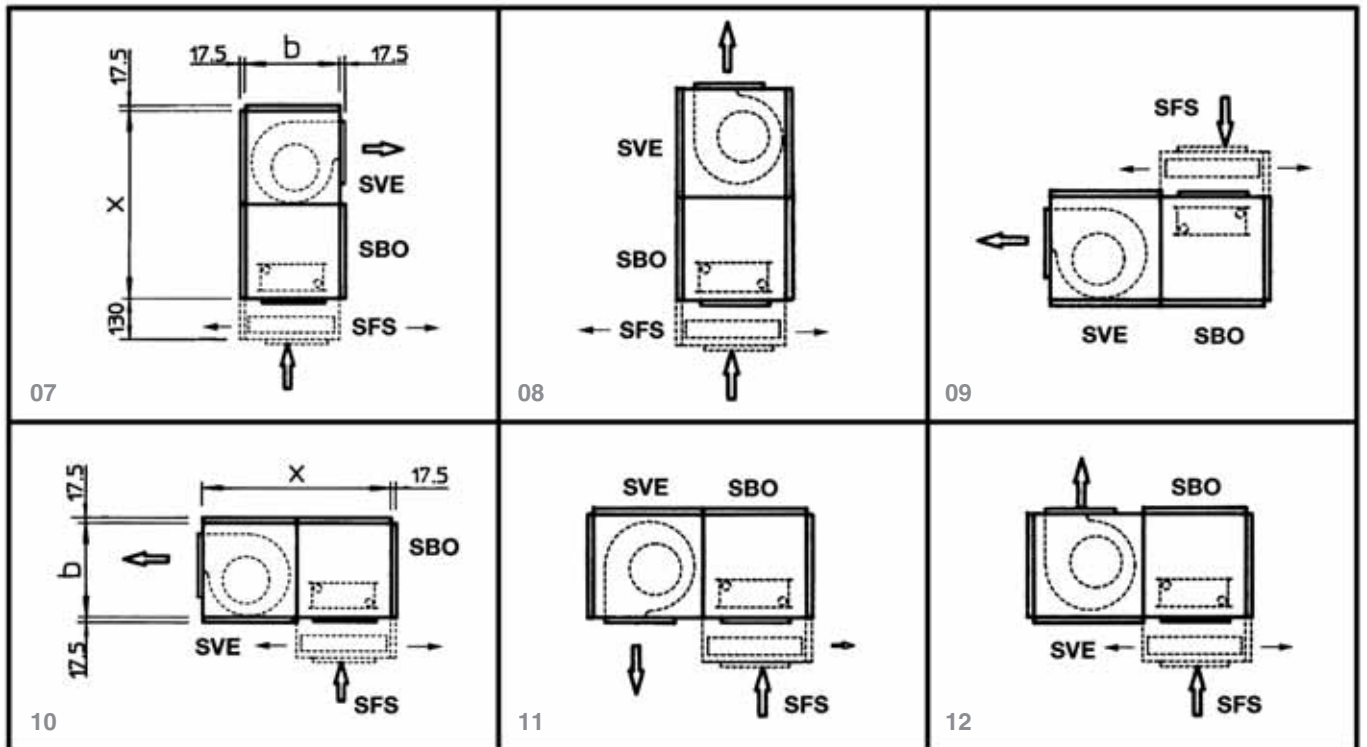

Fan section graphs

Fan section

The fan section can be used for ventilation or as an air extraction box.

The fan performance curve shows the air flow and the available static pressure for each speed at the mouth of the fan.

Maximum Absorbtion AMP			
Size	High	Medium	Low
1	2	1,6	1
2	2,8	1,7	1,2
3	4,4	3,8	3,3
4	6	4	3

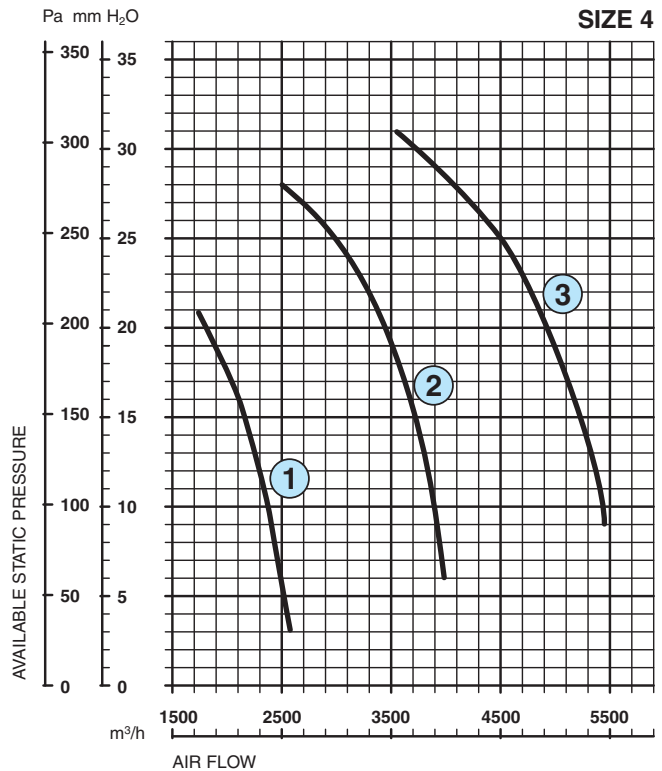
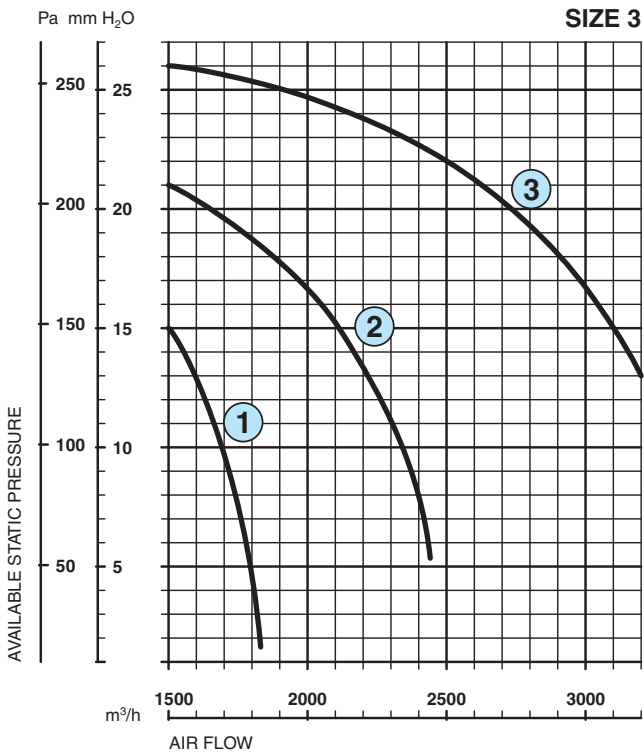
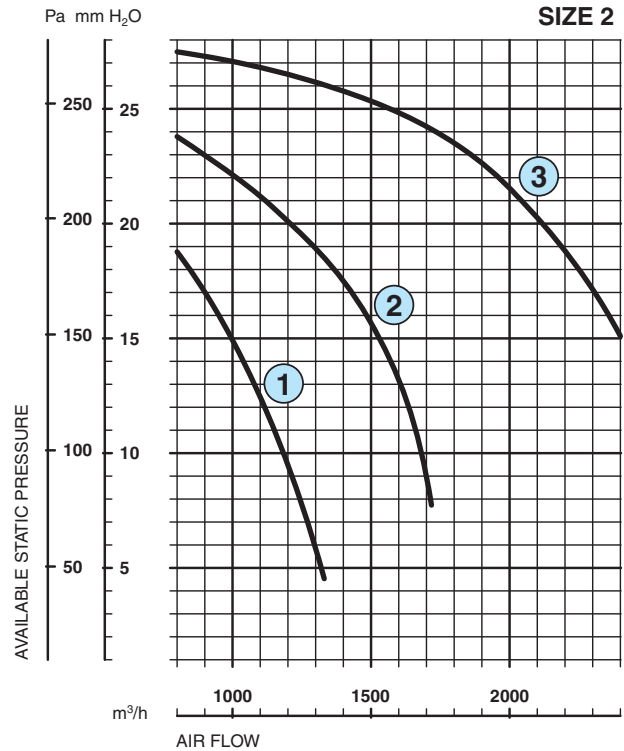
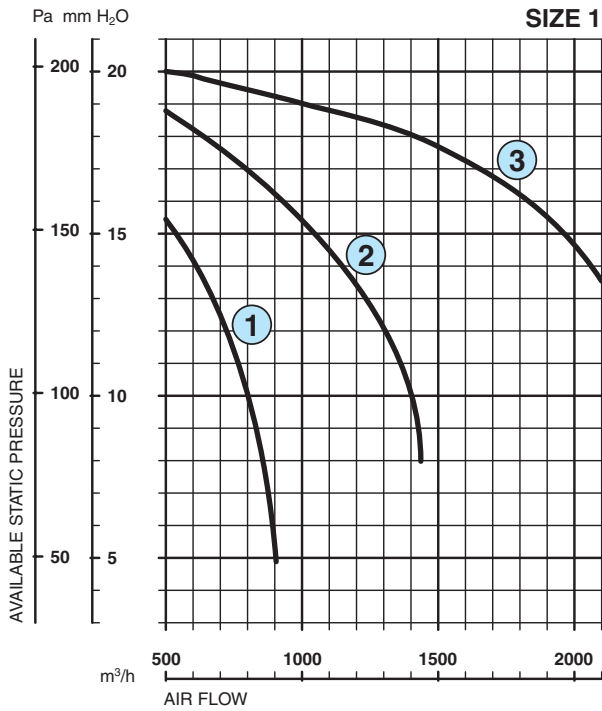

NOTE: ① ② ③ fan speed.

The curves show the available static pressure of the fan at its various speeds. To find out the available static pressure of the Ocean Unit you have to deduct the pressure drop of each component fitted in the unit. This information can be found in the pressure drop diagram on page 7.

Air side pressure drop diagram for internal components

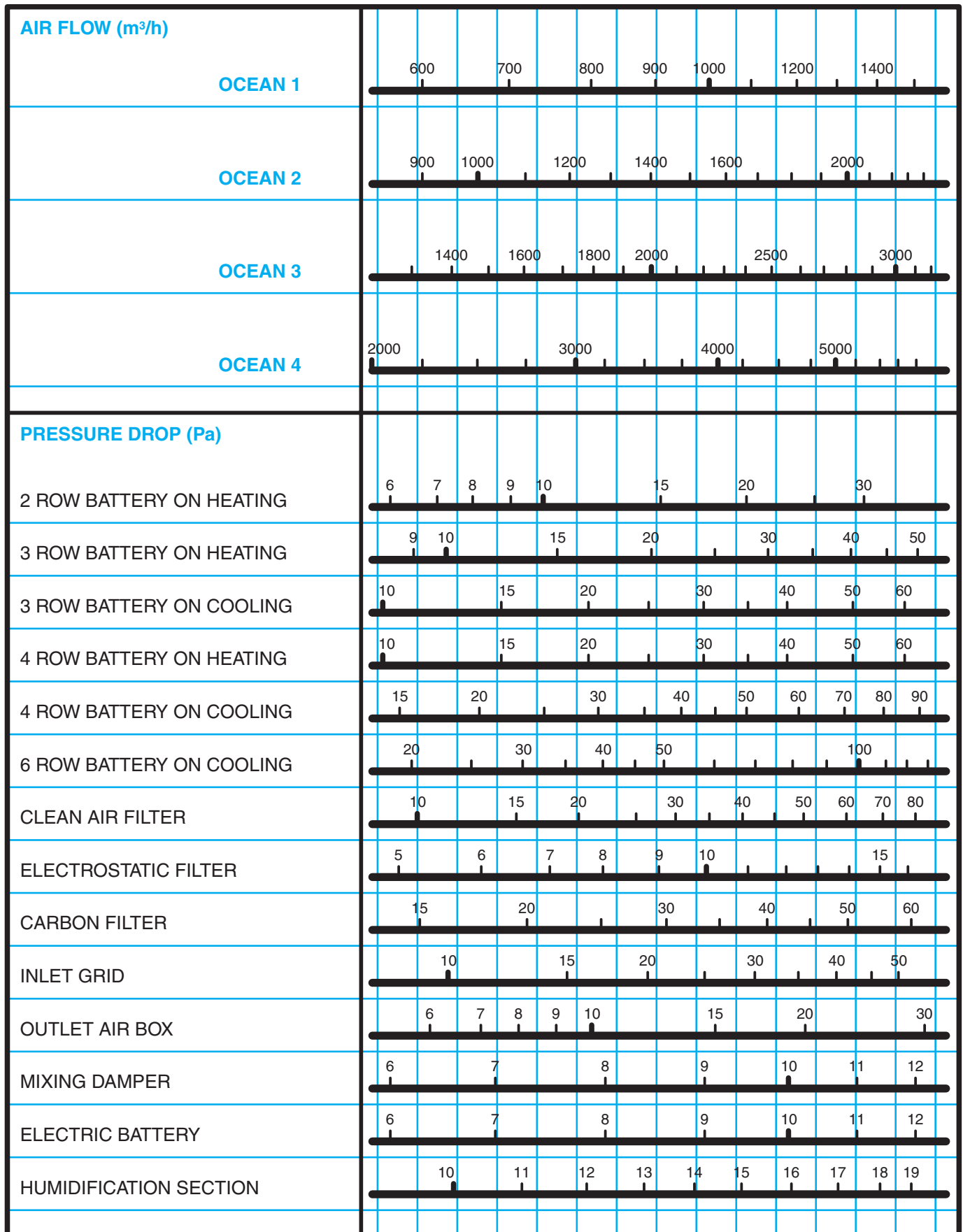

Heating emission (kW)

OCEAN Size	Air flow m ³ /h	Battery rows	Water °C 50/45			Water °C 70/60			Water °C 80/70		
			Air °C			Air °C			Air °C		
			0	+ 10	+ 20	0	+ 10	+ 20	0	+ 10	+ 20
1	600	2	5.9	4.5	3.2	8.0	6.5	5.1	9.3	7.8	6.4
		3	7.5	5.7	4.0	10.1	8.3	6.5	11.7	9.9	8.1
		4	8.4	6.3	4.6	11.5	9.4	7.4	13.3	11.2	9.1
	1000	2	8.5	6.5	4.5	11.5	9.5	7.4	13.5	11.3	9.2
		3	11.1	8.5	6.0	15.2	12.4	9.8	17.6	14.8	12.1
		4	12.8	9.8	7.0	17.6	14.4	11.4	20.4	17.1	14.0
	1400	2	10.8	8.2	5.8	14.6	12.0	9.5	17.0	14.3	11.7
		3	14.3	10.9	7.7	19.5	16.0	12.6	22.7	19.1	15.6
		4	16.8	12.8	9.1	23.1	18.9	15.0	26.8	22.4	18.4

OCEAN Size	Air flow m ³ /h	Battery rows	Water °C 50/45			Water °C 70/60			Water °C 80/70		
			Air °C			Air °C			Air °C		
			0	+ 10	+ 20	0	+ 10	+ 20	0	+ 10	+ 20
2	1000	2	9.5	7.3	5.1	12.9	10.6	8.4	15.1	12.6	10.3
		3	12.1	9.2	6.5	16.6	13.5	10.7	19.2	16.1	13.2
		4	13.8	10.4	7.4	18.9	15.4	12.2	21.9	18.3	15.0
	1550	2	13.1	10.0	7.0	17.8	14.5	11.4	20.7	17.3	14.2
		3	17.1	13.0	9.2	23.3	19.1	15.1	27.1	22.7	18.6
		4	19.8	15.1	10.7	27.2	22.2	17.6	31.4	26.3	21.6
	2100	2	16.2	12.3	8.6	21.9	17.9	14.2	25.6	21.5	17.6
		3	21.5	16.4	11.5	29.4	24.0	19.0	34.0	28.6	23.4
		4	25.3	19.3	13.7	34.6	28.3	22.4	40.2	33.7	27.6

OCEAN Size	Air flow m ³ /h	Battery rows	Water °C 50/45			Water °C 70/60			Water °C 80/70		
			Air °C			Air °C			Air °C		
			0	+ 10	+ 20	0	+ 10	+ 20	0	+ 10	+ 20
3	1500	2	14.3	11.0	7.7	19.4	15.9	12.6	22.7	18.9	15.5
		3	18.2	13.8	9.8	24.9	20.3	16.1	28.8	24.2	19.8
		4	20.7	15.6	11.1	28.4	23.1	18.3	32.9	27.5	22.5
	2100	2	17.7	13.6	9.5	24.1	19.6	15.4	28.0	23.4	19.2
		3	23.2	17.6	12.5	31.6	25.9	20.5	36.7	30.8	25.2
		4	26.8	20.5	14.5	36.9	30.1	23.8	42.5	35.6	29.3
	3000	2	23.1	17.6	12.3	31.3	25.6	20.3	36.6	30.7	25.2
		3	30.7	23.4	16.4	42.0	34.3	27.2	48.6	40.9	33.4
		4	36.2	27.6	19.6	49.4	40.4	32.0	57.4	48.2	39.4

OCEAN Size	Air flow m ³ /h	Battery rows	Water °C 50/45			Water °C 70/60			Water °C 80/70		
			Air °C			Air °C			Air °C		
			0	+ 10	+ 20	0	+ 10	+ 20	0	+ 10	+ 20
4	2400	2	22.8	17.4	12.3	31.1	25.6	20.3	36.4	30.7	25.3
		3	28.9	22.3	15.9	39.8	32.9	26.2	46.2	39.1	32.3
		4	33.3	25.6	18.3	45.9	37.9	30.2	53.1	44.9	37.1
	3800	2	31.1	23.8	16.8	42.3	34.8	27.6	49.5	41.9	34.5
		3	40.5	31.2	22.3	55.7	46.0	36.7	64.7	54.7	45.3
		4	47.6	36.6	26.1	65.6	54.1	43.2	76.0	64.3	53.1
	5300	2	38.4	29.4	20.7	52.2	43.0	34.1	61.1	51.7	42.6
		3	51.0	39.3	28.0	69.9	57.8	46.1	81.2	68.9	57.0
		4	60.8	46.8	33.4	83.6	69.0	55.1	97.1	82.1	67.9

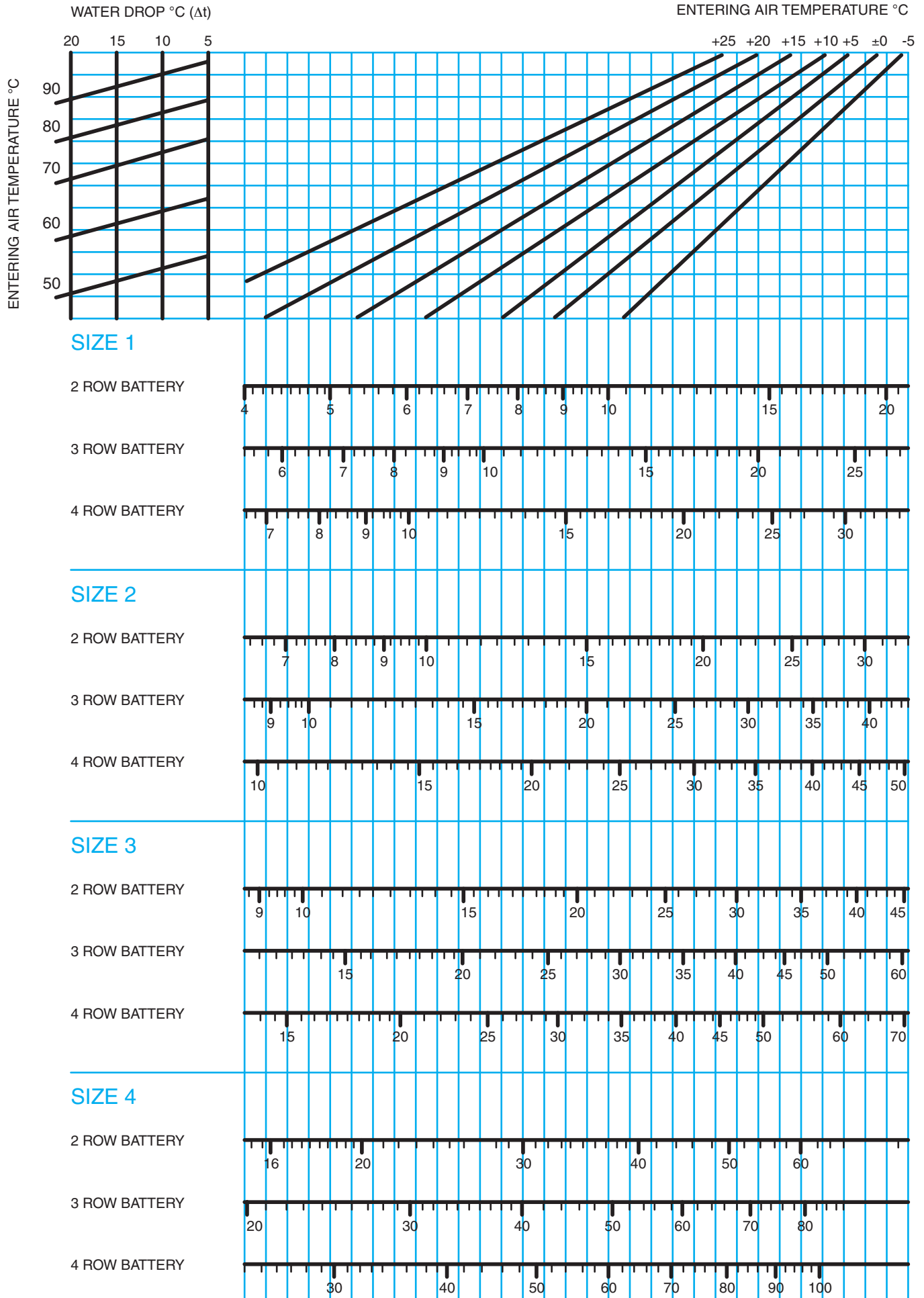

NOTE: Emission at high speed.
 For emission figures at medium speed multiply by 0.75.
 For emission figures at low speed multiply by 0.55.

Cooling emission (kW) with 55% RH

TOTAL

SENSIBLE

OCEAN Size	Air flow m³/h	Battery rows	Water temperature 7/12 °C						Water temperature 12/17 °C					
			Entering Air temperature, dry bulb °C						Entering Air temperature, dry bulb °C					
			+26		+30		+32		+26		+30		+32	
1	600	3	3.2	2.2	4.8	2.9	5.7	3.0	1.6	1.4	2.9	1.9	3.8	2.2
		4	3.7	2.6	5.6	3.5	6.7	3.8	1.8	1.7	3.4	2.2	4.5	2.6
		6	4.8	3.0	7.0	3.8	8.1	4.1	2.2	2.0	4.6	2.8	5.8	3.2
	1000	3	4.3	3.2	6.6	4.0	7.9	4.3	2.3	2.3	3.9	3.0	5.1	3.4
		4	5.2	3.7	8.0	4.6	9.4	5.1	2.7	2.7	4.7	3.5	6.2	3.9
		6	7.1	4.6	10.4	5.7	12.2	6.3	3.1	3.1	6.6	4.3	8.4	4.8
	1400	3	5.2	4.0	8.0	5.0	9.6	5.4	2.8	2.8	4.6	3.8	6.1	4.3
		4	6.4	4.7	9.8	5.9	11.6	6.4	3.4	3.4	5.7	4.4	7.6	5.0
		6	9.0	6.0	13.3	7.5	15.6	8.2	4.5	4.5	8.3	5.6	10.6	6.3
2	1000	3	5.6	3.8	8.3	4.7	9.8	5.1	2.8	2.8	5.1	3.5	6.6	4.0
		4	5.8	4.1	9.0	5.1	10.7	5.6	3.2	3.2	6.0	4.0	7.8	4.5
		6	7.2	4.7	10.8	6.0	12.7	6.5	3.4	3.4	6.7	4.4	8.7	5.0
	1550	3	6.7	5.1	10.4	6.4	12.5	6.9	3.5	3.5	6.0	4.8	8.0	5.4
		4	7.9	5.8	12.3	7.3	14.7	8.0	4.0	4.0	7.0	5.4	9.4	6.1
		6	10.3	7.0	15.5	8.7	18.3	9.5	4.9	4.9	9.5	6.4	12.3	7.3
	2100	3	8.0	6.4	12.5	7.9	14.9	8.6	4.4	4.4	7.0	6.0	9.5	6.8
		4	9.6	7.3	14.9	9.1	17.8	9.9	5.1	5.1	8.5	6.9	11.4	7.8
		6	13.0	9.0	19.5	11.1	23.0	12.2	6.4	6.4	11.8	8.3	15.4	9.4
3	1500	3	7.8	5.6	11.8	6.9	14.0	7.5	3.9	3.9	7.0	5.2	9.2	5.8
		4	9.8	6.5	14.5	8.1	17.1	8.9	4.4	4.4	8.2	5.8	11.6	6.8
		6	11.9	7.6	17.3	9.4	20.2	10.3	5.4	5.4	11.2	7.0	14.5	7.9
	2100	3	10.2	7.4	15.4	9.1	18.2	9.9	5.4	5.4	9.3	6.9	12.0	7.7
		4	12.2	8.5	18.3	10.5	21.6	11.4	6.2	6.2	11.2	7.8	14.5	8.9
		6	15.4	10.0	22.5	12.4	26.4	13.6	6.6	6.6	14.3	9.2	18.3	10.4
	3000	3	12.5	9.5	18.9	11.6	22.3	12.5	6.8	6.8	11.2	8.9	14.6	9.9
		4	15.2	11.0	22.9	13.5	27.0	14.7	8.1	8.1	13.7	10.3	17.9	11.5
		6	19.7	13.3	29.2	16.4	34.3	17.9	10.0	10.0	18.1	12.3	23.3	13.8
4	2400	3	11.8	8.2	17.8	10.2	21.0	11.1	5.9	5.9	10.7	7.7	14.0	8.6
		4	15.0	9.9	22.0	12.3	25.9	13.4	7.2	7.2	13.9	9.2	17.8	10.4
		6	17.6	11.2	25.4	13.8	29.6	15.1	8.4	7.6	16.6	10.4	20.9	11.7
	3800	3	15.5	11.4	23.5	14.0	27.9	15.8	8.1	8.1	13.9	10.6	18.3	11.9
		4	20.3	14.0	30.1	17.2	35.4	18.7	10.2	10.2	17.3	12.5	22.4	14.1
		6	24.5	16.1	35.6	19.8	41.6	21.5	11.3	11.0	22.9	14.9	28.9	16.7
	5300	3	18.5	14.2	28.2	17.4	33.4	18.9	10.1	10.1	16.5	13.4	21.7	14.9
		4	24.8	17.7	36.8	21.6	43.4	23.5	12.9	12.9	21.1	16.1	27.5	18.0
		6	30.5	20.6	44.5	25.2	52.1	27.4	15.3	15.3	28.2	19.1	35.8	21.4

OceanSabiana size 1 cooling emission graph with 3 row battery.

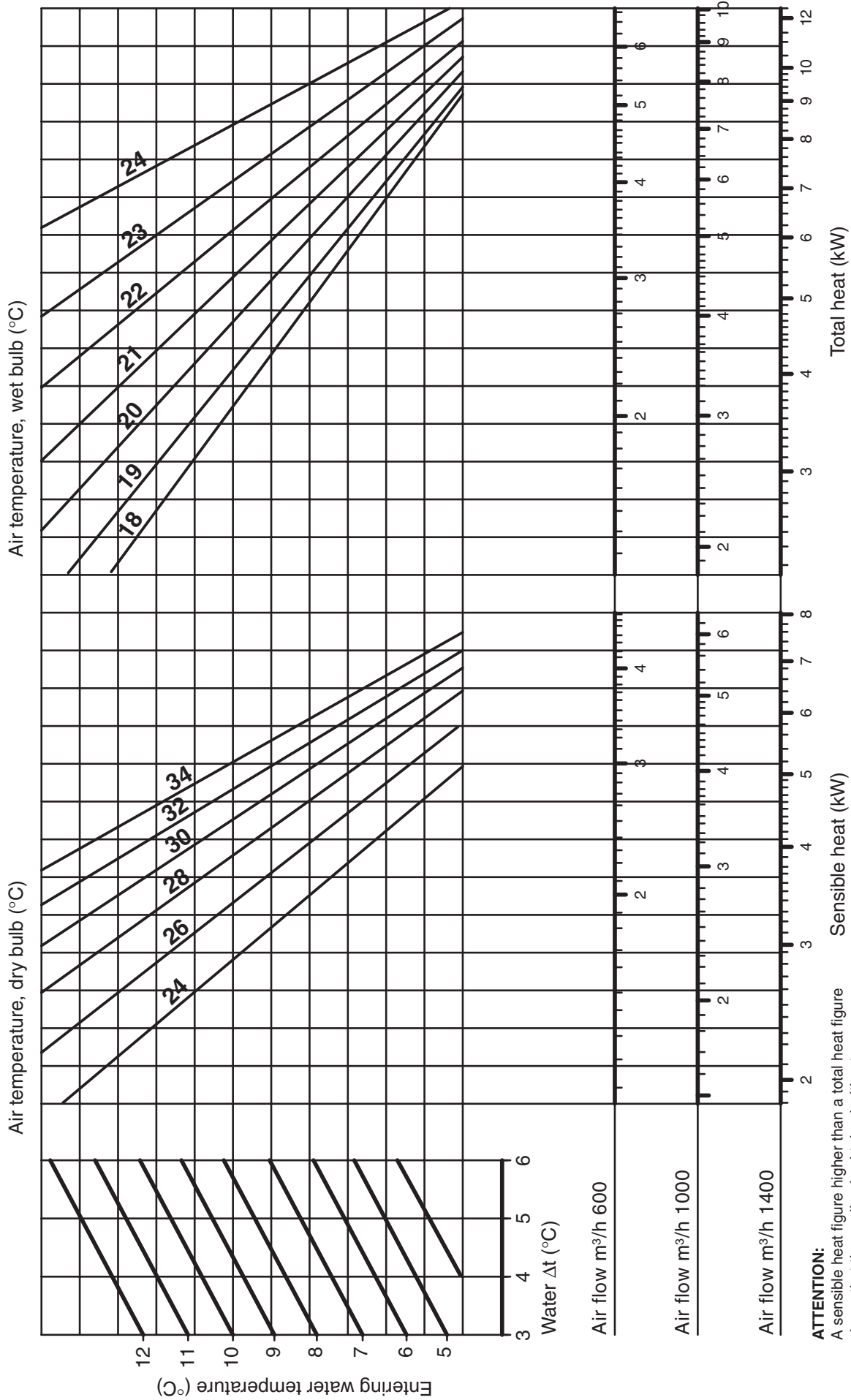

ATTENTION:
A sensible heat figure higher than a total heat figure shows that the cooling is obtained without dehumidification, therefore the emission to refer to is the sensible one.

NOTE:
Do not supply the unit with water at a temperature lower than +5°C.

Output figures of 4 row battery are obtained multiplying the 3 row battery figures of the graph by 1.19

Output figures of 6 row battery are obtained multiplying the 3 row battery figures of the graph by 1.45

OceanSabiana size 2 cooling emission graph with 3 row battery.

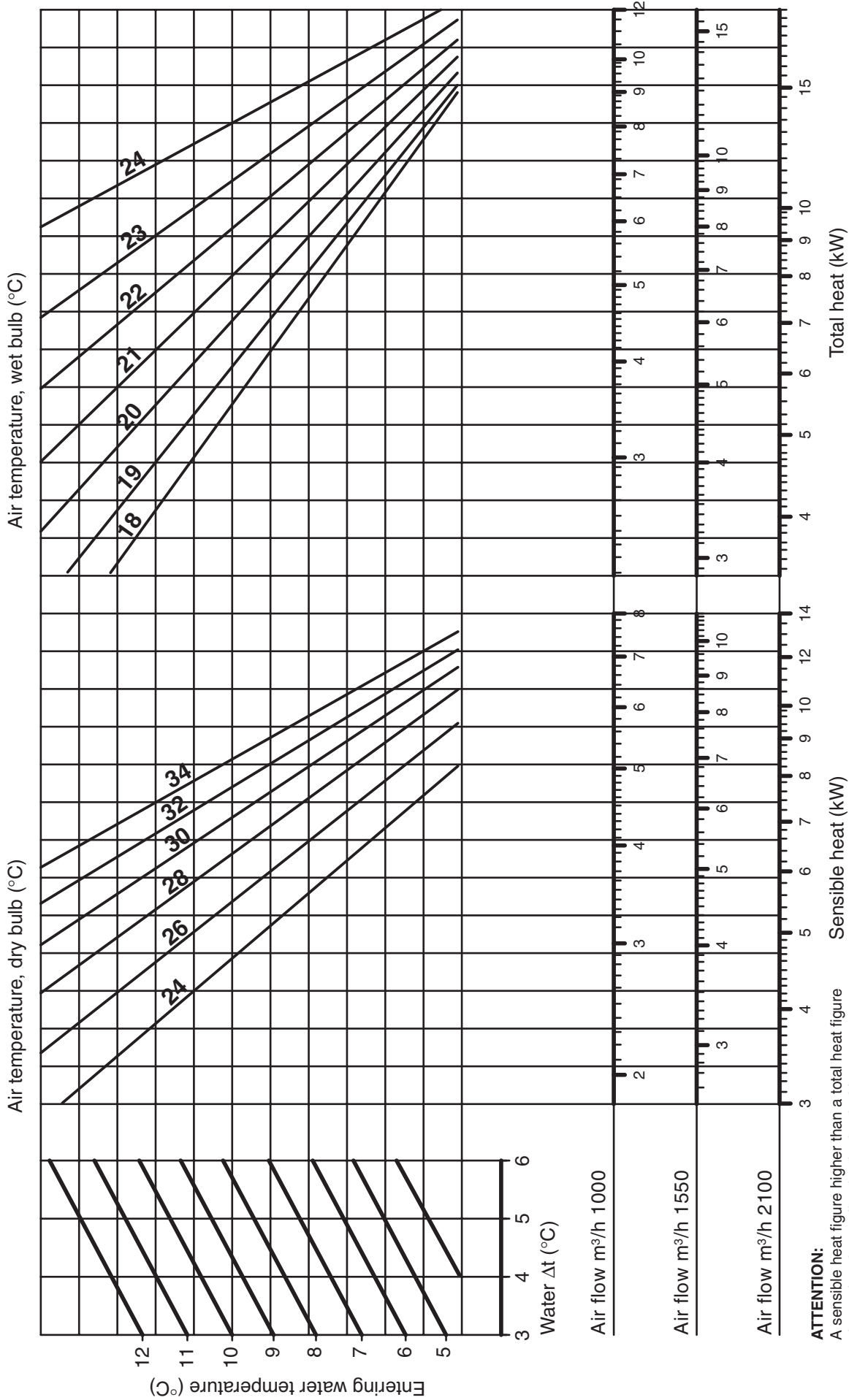

ATTENTION:

A sensible heat figure higher than a total heat figure shows that the cooling is obtained without dehumidification, therefore the emission to refer to is the sensible one.

NOTE:

Do not supply the unit with water at a temperature lower than +5°C.

Output figures of 4 row battery are obtained multiplying the 3 row battery figures of the graph by 1.19

Output figures of 6 row battery are obtained multiplying the 3 row battery figures of the graph by 1.45

OceanSabiana size 3 cooling emission graph with 3 row battery.

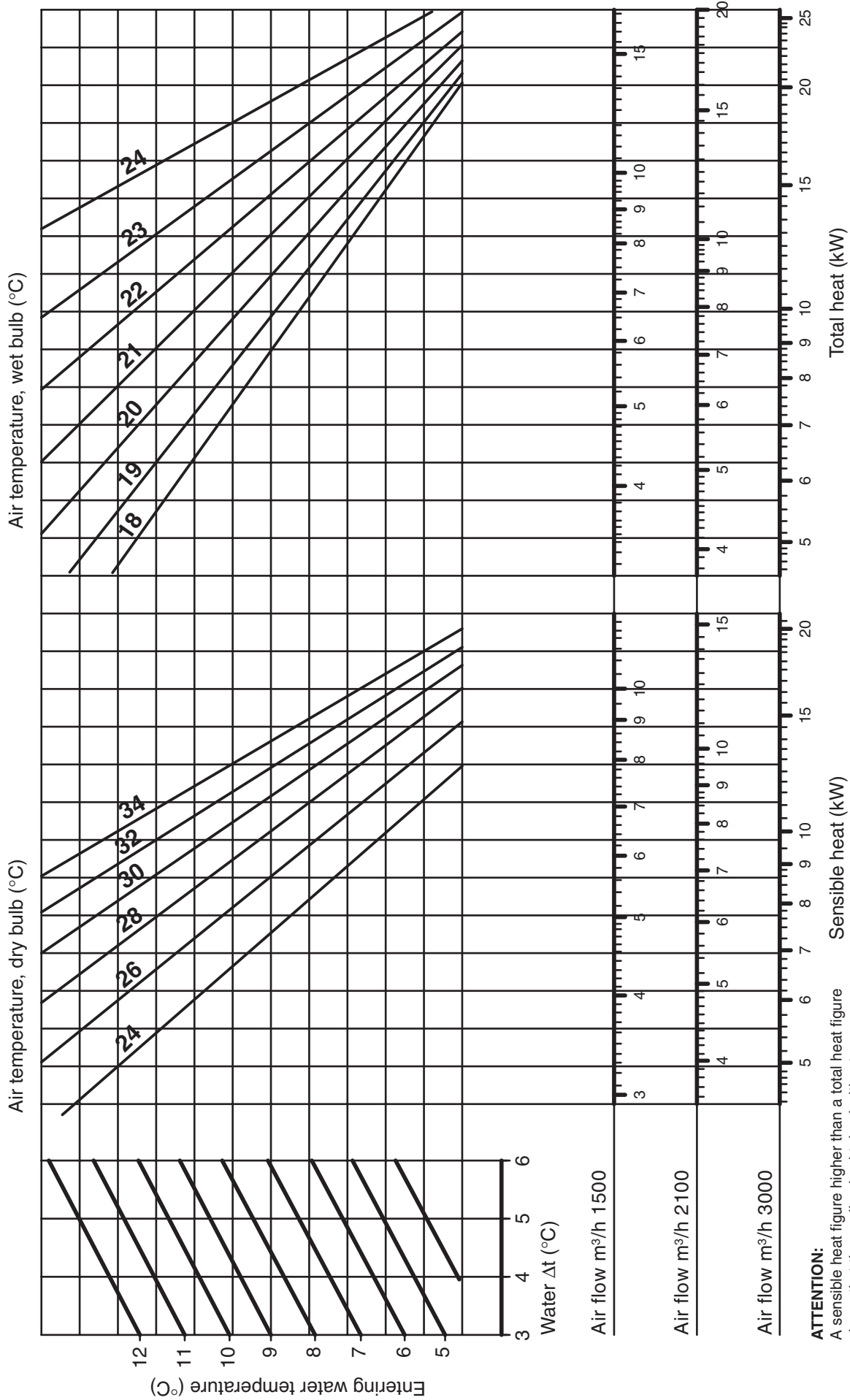

ATTENTION:
A sensible heat figure higher than a total heat figure shows that the cooling is obtained without dehumidification, therefore the emission to refer to is the sensible one.

NOTE:
Do not supply the unit with water at a temperature lower than +5°C.

Output figures of 4 row battery are obtained multiplying the 3 row battery figures of the graph by 1.19

Output figures of 6 row battery are obtained multiplying the 3 row battery figures of the graph by 1.45

OceanSabiana size 4 cooling emission graph with 3 row battery.

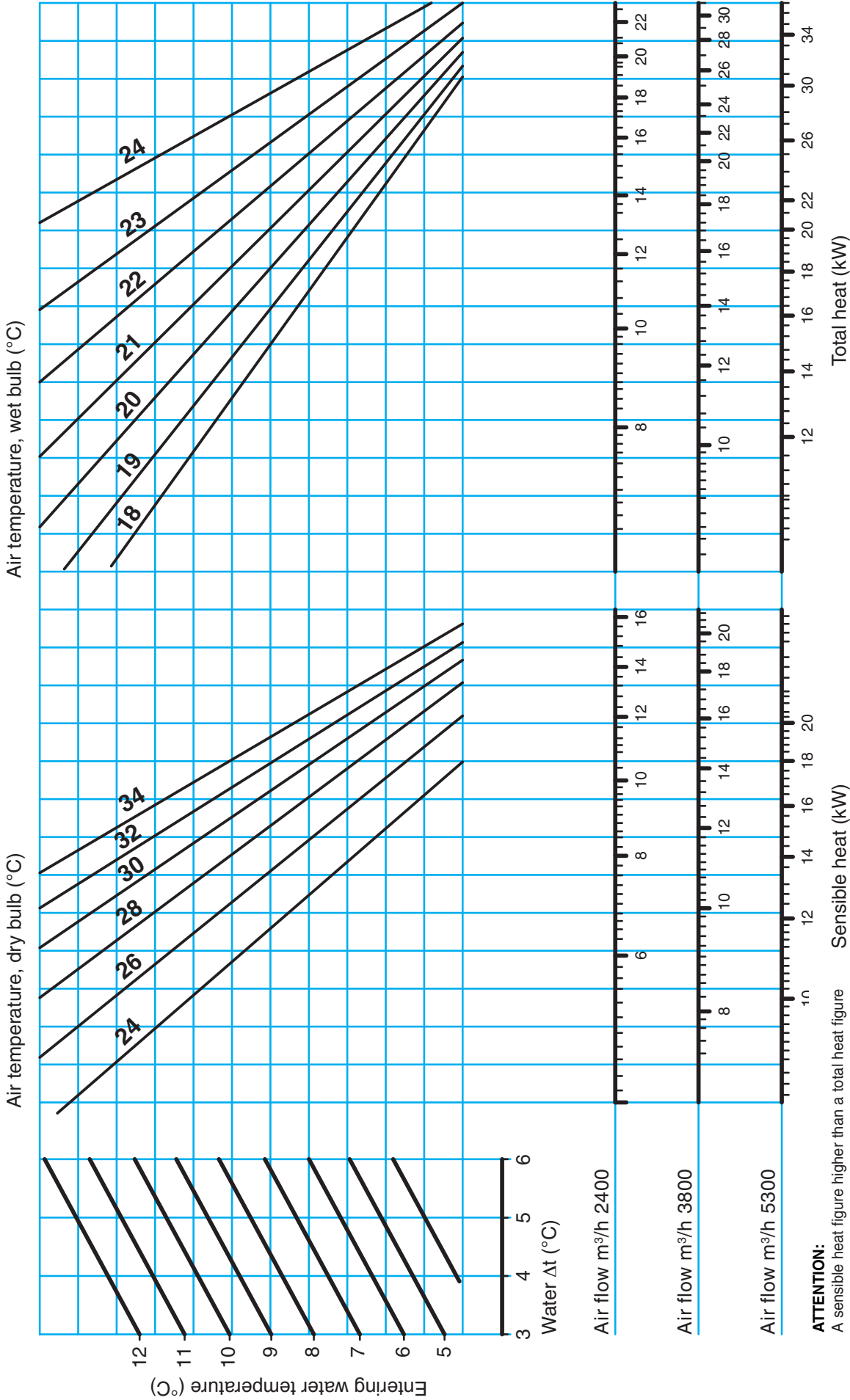

ATTENTION:

A sensible heat figure higher than a total heat figure shows that the cooling is obtained without dehumidification, therefore the emission to refer is the sensible one.

NOTE:

Do not supply the unit with water at a temperature lower than +5°C.

Output figures of 4 row battery are obtained multiplying the 3 row battery figures of the graph by x 1.19

Output figures of 6 row battery are obtained multiplying the 3 row battery figures of the graph by x 1.45

Unit with 4 row direct expansion battery
Cooling emission kW

Direct expansion batteries

The air treatment section of the Ocean series can be fitted with a direct expansion battery. These sections have to be connected to a condenser unit with performances suitable to the emissions shown in the table.

The air side pressure drop of these batteries is the same shown in the diagram at page 7 for a 4 row battery on cooling.

R.22 Expansion +5°C Entering air temperature +25°C 55% R.H.

SIZE 1

Air flow m³/h	600	1000	1400
Total heat kW	4.1	6.4	8.3
Sensible heat kW	3.1	4.8	6.2

SIZE 2

Air flow m³/h	1000	1550	2100
Total heat kW	6.7	9.8	12.5
Sensible heat kW	5.0	7.3	9.4

SIZE 3

Air flow m³/h	1500	2100	3000
Total heat kW	10.3	12.9	16.3
Sensible heat kW	7.7	9.7	12.2

SIZE 4

Air flow m³/h	2400	3800	5300
Total heat kW	15.5	22.0	26.1
Sensible heat kW	10.0	14.6	18.0

NOTE: For correct working of the unit it must be installed a thermostatic valve (not supplied)

Water pressure drop

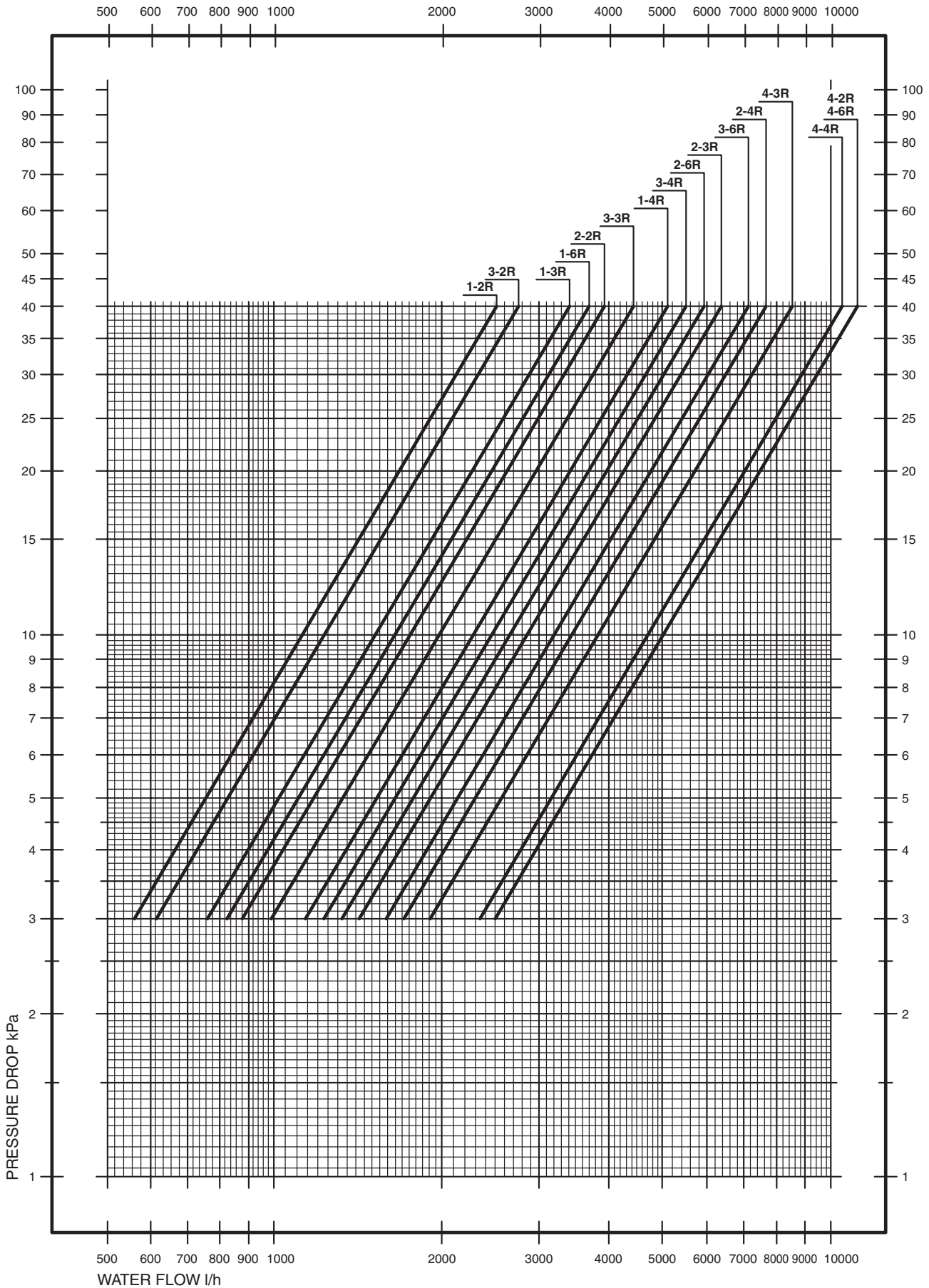

The table shows the water pressure drop in kPa (10 kPa = about 1 m of W.G.) of each unit with either 2, 3, 4, or 6 row battery against the water flow in l/hr at a mean water temperature of 75°C. For different M.W.T. the correction factor (K) must be applied.

°C	10	20	30	40	50	60	70	80	90
K	1.39	1.33	1.27	1.21	1.15	1.09	1.03	0.97	0.91

Electrostatic filter and carbon filter

(only for OCEAN sizes 1-2-3)

ELECTROSTATIC FILTER

The CRYSTALL SABIANA electrostatic filter matches the need for better air conditioning with the concepts of space and design. With this filter the various stages of air treatment are combined in

one appliance. Thanks to this new patented filter, air pollutants such as cigarette smoke, dust, pollen and most biological organisms are eliminated. In addition, as fresh air is not

being introduced to obtain the best climatic conditions, there are consequential energy savings.

CARBON FILTER

On request, the carbon filter can also be fitted in the electrostatic filter section. It is highly efficient for the purification of the air from gaseous pollutants and odours.

OPERATING PRINCIPLE OF THE ELECTROSTATIC FILTER CRYSTALL SABIANA

The air is sucked in and first passes a mechanical prefilter, which keeps away particles of more than 50 μm (dust, insects, etc.).

(Phase 1)

Then the smallest particles (50 \div 0.01 μm) are exposed to an intensive ionic field and are polarized.

(Phase 2)

The charged particles passing through the second filter section, are pushed back by the anode and attracted to the collection surfaces by a strong, inducted magnetic field.

(Phase 3)

The air which leaves the unit is free from polluting particles.

The carbon filter (supplied on request) purifies the air from gaseous pollutants and from odours.

(Phase 4)

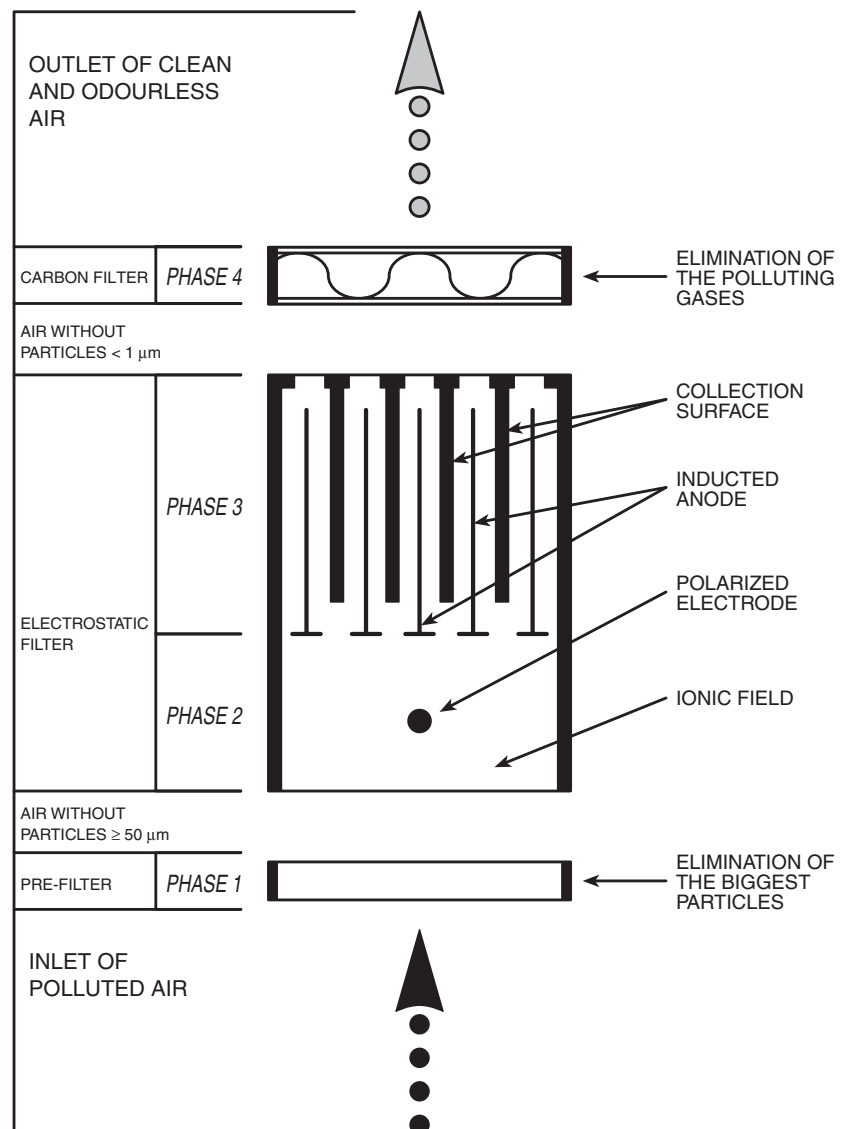

The STD ASHRAE 62-1989 regulations

The ASHRAE 62-89 standard defines as “acceptable” the air in a closed environment, which does not present such concentrations of known polluting agents so as to represent a danger to the health of the people in the room and where more than 80% of these people do not show signs of suffering. The simplest way to obtain the requested air quality is to dilute the existing polluting agents by introducing fresh air. The quantity of fresh air to introduce according to the ASHRAE 62-1989 standard is indicated in the table on the next page.

example	particle Ø µm	origin	dangers	annotations
pollen	10 ÷ 100	Outdoor Indoor	May cause harmful allergic reactions	Derived from plants in certain periods of the year
moulds	3 ÷ 10	Indoor Outdoor	May cause allergic reactions	Present during the whole year with max. concentrations during wet periods and in humid environments
bacteria	0.3 ÷ 30	Indoor Outdoor pipes filters	Eventual diseases	They can be transported on other particles, on the body and the clothes
virus	0.01 ÷ 0,05	humidifiers		
carbon powder	0.02 ÷ 2	Outdoor (Indoor)		
synthetic and mineral fibre	0.1 ÷ 2	Outdoor Indoor	Irritation of the skin, the lungs and the eyes	From building materials and textile products
lead powder	0.1 ÷ 0.6	Outdoor	Neurological problems in children	
tobacco smoke	0.01 ÷ 4	Indoor	A high risk of lung cancer, respiratory diseases, irritations of the eyes, the nose and the throat, allergic and olfactory problem	Inhaled particles (< 1µm)
burnt kitchen oil	0.3 ÷ 10	Indoor (origin: cooking)	Olfactory problem	Particles that can be inhaled
wood combustion	2 ÷ 30	Indoor Outdoor (origin: cooking)	May cause allergic reactions	(origin: cooking)
radon	0.005 ÷ 1	Outdoor Indoor	Carcinogenic	Product of uranium decay; present in the soil, in slag blocks, etc.

PARTICLES IN INDOOR ENVIRONMENTS: DIMENSION AND DANGERS

Recommended fresh air inlet levels for environmental ventilation according to the regulations of ASHRAE STD 62-1989

Type of environments	max. occupation with persons /100m ²	fresh air inlet levels m ³ /h per person	L/s per person
meeting rooms	50	36.5	10
cocktail bars/lounges	100	54 (1)	15 (1)
restaurants	70	36 (1)	10 (1)
hotel rooms		54 (2)	15 (2)
offices	7	36	10
coffe-house-fast food	100	36	10
schoolrooms	50	29	8
smoking rooms	70	108 (3)	30 (3)
residences		(4)	(4)
big department stores			
• ground floor and basement	30	5.4 (5)	1.5 (5)
• upper floors	20	3.6 (5)	1.0 (5)
• dressing rooms	-	3.6 (5)	1.0 (5)
• stores	5	2.7 (5)	0.75 (5)
theatres ticket offices	60	36	10
theatres miscellaneous	150	36	10
theatres audience-room	150	29	8
shops		18 (5)	5 (5)

ASHRAE 62-1989 standard:

- 1) The use of an high-efficiency filter is recommended
- 2) L/s m²/h per room
- 3) Spotted air extractions are recommended
- 4) 0.35 volume/hour, but not less than 8 L/s (29 m²/h) per person
- 5) L/s m²/h per square metre of surface

Concentration of CO₂ in an environment with different fresh air inlets

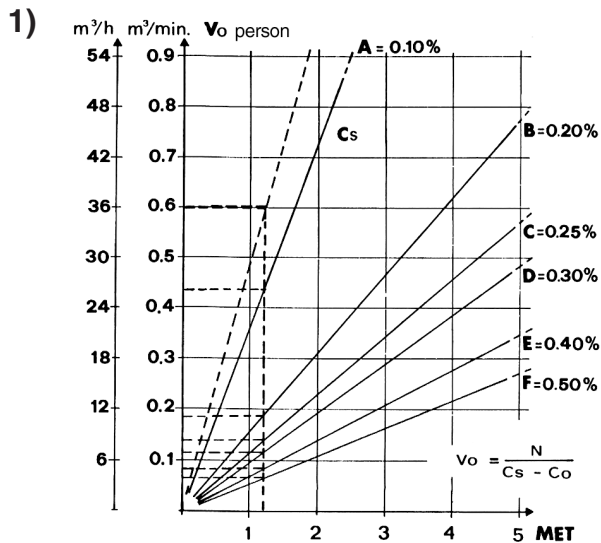

$C_s = 1000$ ppm = 26 m³/h person (V_o) (A) Example of the CO₂
 = 2000 " = 11 " " " (B) concentration with
 = 2500 " = 8,5 " " " (C) a phisycal activity
 = 3000 " = 7 " " " (D) of 1.2 MET.
 = 4000 " = 5 " " " (E)
 = 5000 " = 4 " " " (F) (1 MET = 18.4 BTU/h x F^{0.75})

Production of polluting particles from cigarette smoke

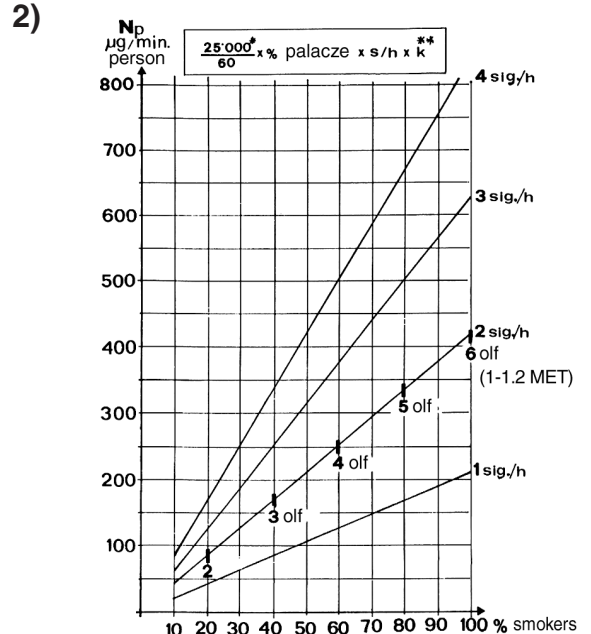

* = Mean quantity of pollutant for each cigarette (Leaderer und Cain 1983)
 ** = K empirical constant ("setting and plating factor" A.E. Wheeler 1988)

Ventilation and air change

It is generally understood, that the more fresh air introduced indoors the better the indoor air quality will be. However, this implies an increase in energy costs necessary to keep comfortable environmental conditions. In addition the external air quality must be controlled year round in order to avoid a pollutant concentration that can jeopardize human health, when introduced indoor through ventilation.

The use of the “CYSTALL” Electrostatic Filter dramatically reduces the external air intake which, in turn, provides a significant energy saving and reduces health risks.

The air treated by an Ocean air-conditioner fitted with an electrostatic filter usually has a concentration of polluting microparticles lower than the external air concentration, which improves the indoor air quality.

The U.S. agencies EPA, OSHA, and the new ASHRAE Standard which is now being approved, set an external air intake minimum value of only 2.5/3L/s per person. This quantity of external air can guarantee a sufficient salubrity rate for the occupants, provided that there are no specific indoor sources of pollutants (ie tobacco, smoke, special activities).

With these recommended values for external air intake and with an OCEAN air-conditioner equipped with a suitably sized electrostatic filter, a high quality of indoor air and comfort level can be obtained.

The table below gives a simple indication of the size of the OCEAN air-conditioner, fitted with the electrostatic filter, required to function efficiently in various installation situations.

Obviously, the large variety of

applications and environment situations possible make difficult a more specific and detailed approach to solving particular problems.

This table has therefore, been drawn up on a general basis assuming that certain values remain constant.

In particular:

- The pollutant quantity produced indoors is relatively low.
- Occupational density is 7p/100m² (7 people for every 100 m² of surface).
- Ventilation efficiency = 2.
- External air quantity <10% of maximum air flow.
- Maximum room height = 3 metres.

OCEAN	AIR FLOW m ³ /h	MAX ROOM VOLUME m ³	MAX NUMBER OF PEOPLE
1	650	160	4
	1000	250	6
	1400	350	8
2	1150	280	6
	1550	380	8
	2100	520	12
3	1750	430	9
	2300	570	12
	3000	750	17
4	2500	620	13
	3800	950	20
	5300	1320	28

“SFE” electrostatic filter section and “FCA” carbon filter

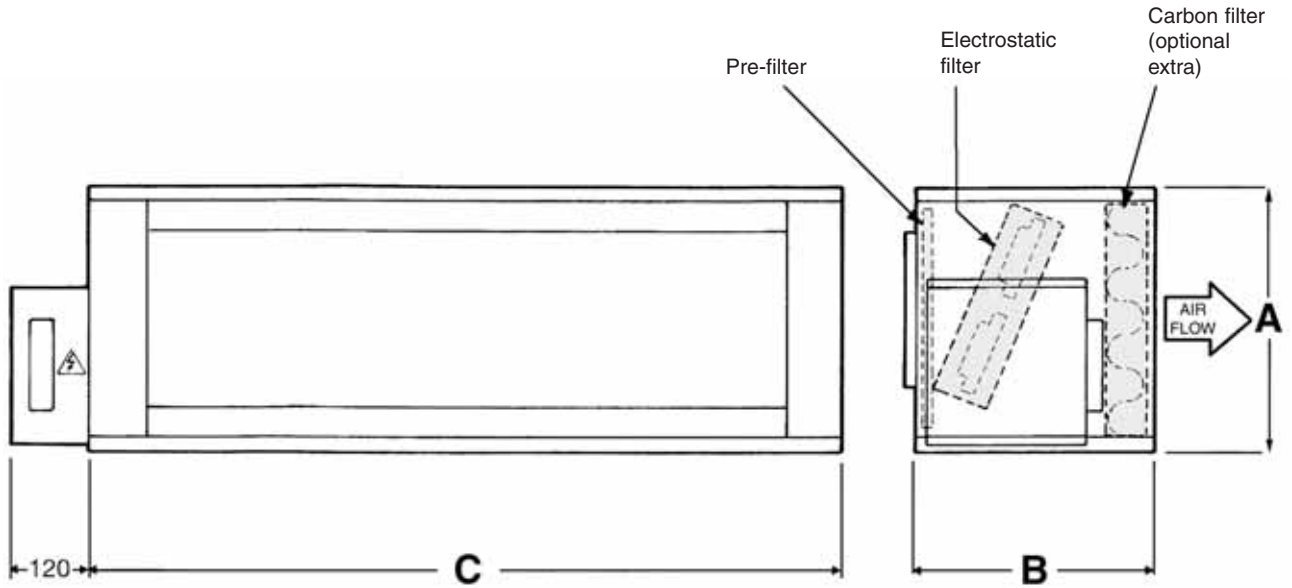

DIMENSIONS				
Model	1	2	3	4
A	335	415	515	515
B	300	380	480	480
C	950	950	950	1500
Electrostatic filter	840x112	840x112	840x112	1390x112
N° electrostatic filter	2	3	4	4
Weight kg	7.8	8.5	10	17

“CIF”

Remote control

3 speed switch
and electrostatic filter switch



Wiring diagram

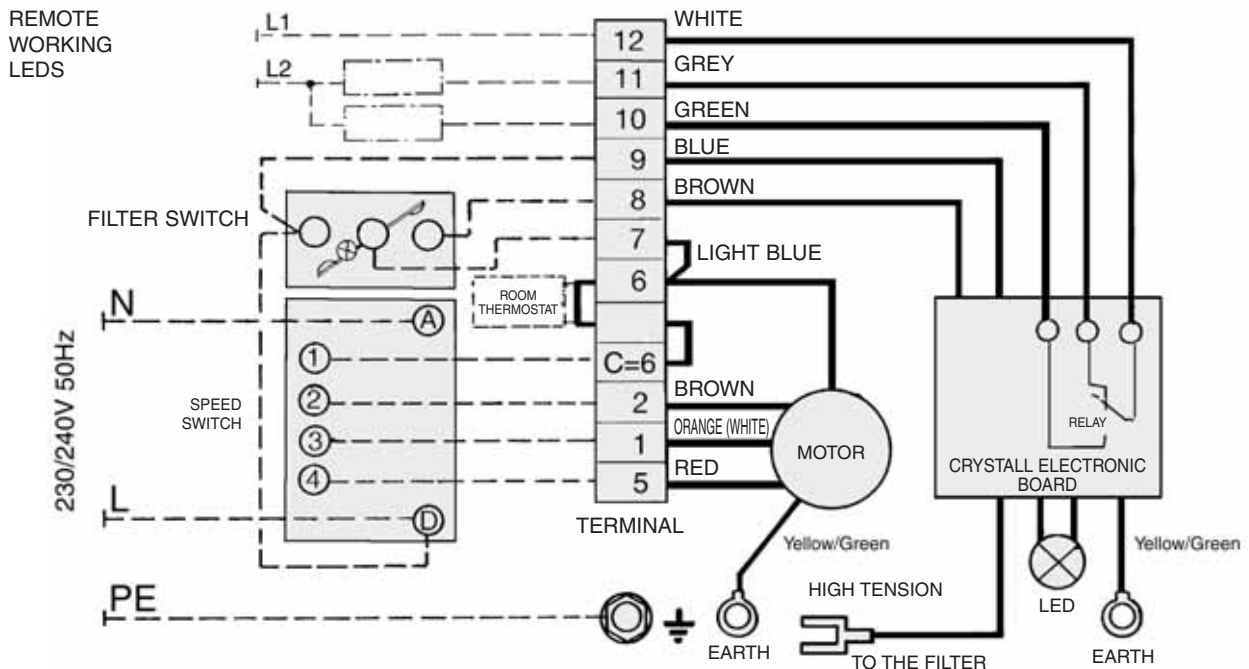

Filter section

“SFS”

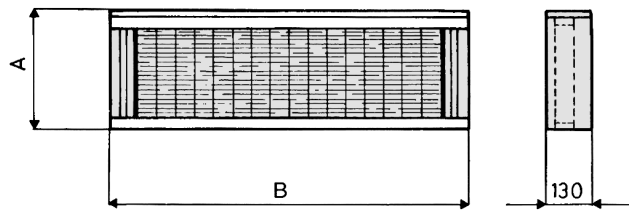

Model	1	2	3	4
A	318	398	498	498
B	950	950	950	1500
Weight kg	7.4	7.9	8.4	11.5

Synthetic, re-usable pleated filter, efficiency according to ASHRAE 84%, Eurovent EU3 class.
 Dimension: model 1 = 290x870x48
 model 2 = 370x870x48
 model 3 = 470x870x48
 model 4 = 470x1420x48

Inlet grid to be installed on the ductwork

“GAS”

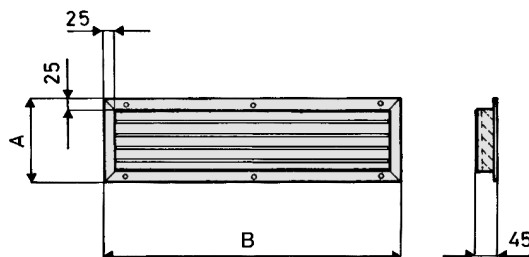

Model	1	2	3	4
A	225	325	425	425
B	820	820	820	1380

Filter section with inlet grid

“FGR”

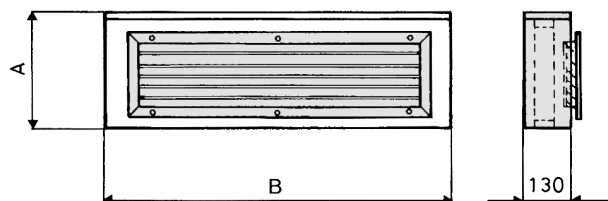

Model	1	2	3	4
A	318	398	498	498
B	950	950	950	1500

Inlet box with grid

“PAG”

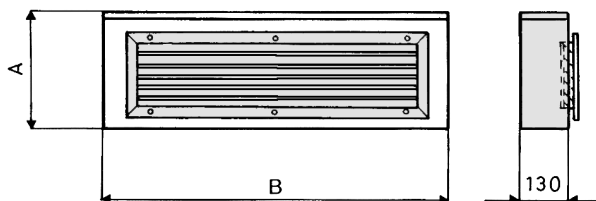

Model	1	2	3	4
A	318	398	498	498
B	950	950	950	1500

Filter section with damper

“FSR”

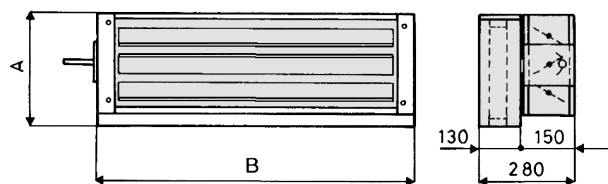

Model	1	2	3	4
A	318	398	498	498
B	950	950	950	1500

Panel with inlet grid to be installed on the fan section or on the air box

“PGA”

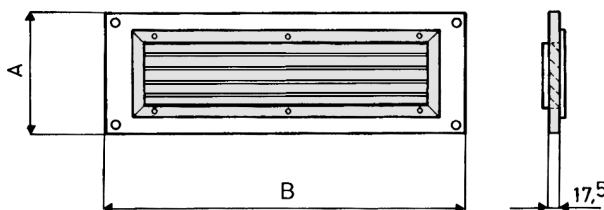

Model	1	2	3	4
A	300	380	480	480
B	950	950	950	1500

Inlet damper

“SRA”

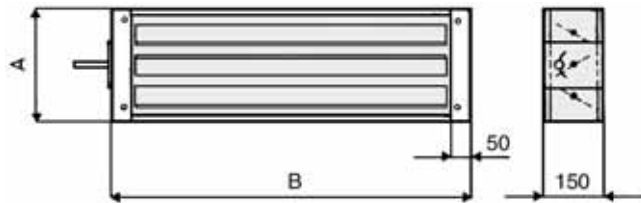

Model	1	2	3	4
A	300	380	480	480
B	950	950	950	1500

Outlet box with double louvres

“PMB”

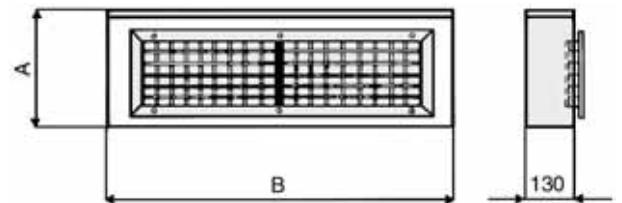

Model	1	2	3	4
A	318	398	498	498
B	950	950	950	1500

Inlet box with damper

“PAS”

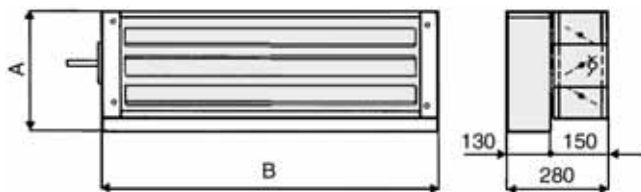

Model	1	2	3	4
A	318	398	498	498
B	950	950	950	1500

Outlet box with circular diffusers

“PMC”

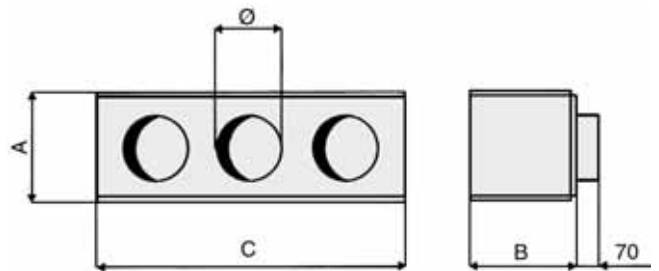

Model	1	2	3	4
A	335	415	515	515
B	318	398	498	498
C	950	950	950	1500
Ø	200	200	200	250

Mixing box with two dampers

“PDS”

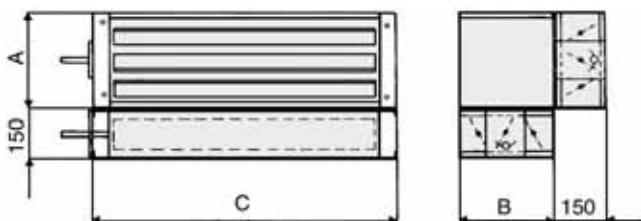

Model	1	2	3	4
A	318	398	498	498
B	300	380	480	480
C	950	950	950	1500

Inlet box with damper

“PMS”

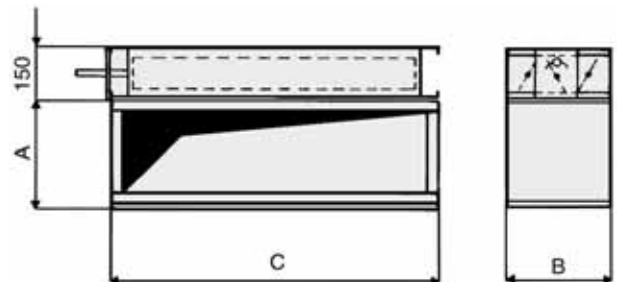

Model	1	2	3	4
A	318	398	498	498
B	300	380	480	480
C	950	950	950	1500

Outlet grid with double louvres

“BMA”

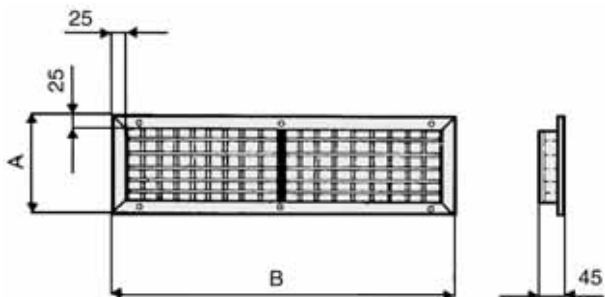

Model	1	2	3	4
A	225	325	425	425
B	820	820	820	1380

Supplementary electric battery

“BEL”

Section with an electrical element incorporating a safety thermostat

NOTE: the electric battery must be fitted after the fan section.

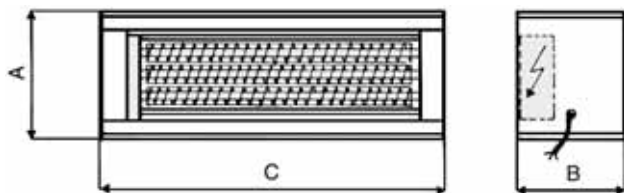

Model	1	2	3	4
A	335	415	515	515
B	300	380	480	480
C	950	950	950	1500
Volt	230/1	230/1	400/3	400/3
kW	2	4	6	12
Steps	1	1	3kW+3kW	6kW+6kW
Weight kg	12	14	16	24

Condensate collection tray

“BRC”

Made in galvanized and painted steel, complete with brackets and securing screws. It is mounted on the bottom of the battery section and has a 15 mm diameter connection. A tube should be connected and taken to a suitable drain.

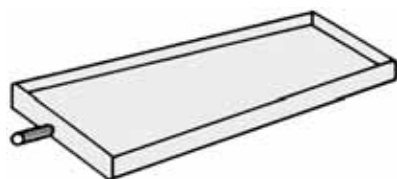

Model	1	2	3	4
Weight kg	2.9	3.9	4.9	7.3

Humidification section

“SUD”

Deck fill humidification with 2-way valve controlled by a room humidification sensor (not supplied).

The maximum water pressure feeding is 2 Bar.

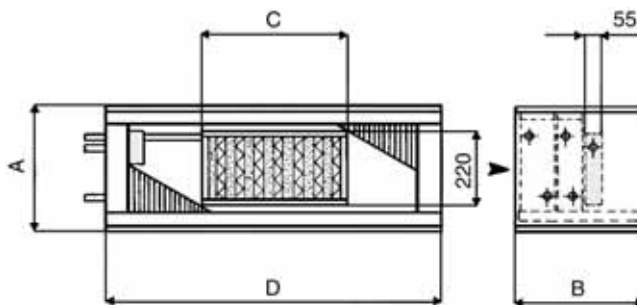

Model	1	2	3	4
A	335	415	515	515
B*	300	380	480	480
B**	600	380	480	480
C	480	480	725	1275
D	950	950	950	1500
E	200	200	420	420

B * = for 2, 3, 4, 6, 4 + 2 row batteries

B ** = for 6 + 2 row batteries

Suspension brackets

“SQS”

Galvanized steel angle brackets for either ceiling mounting or wall mounting.

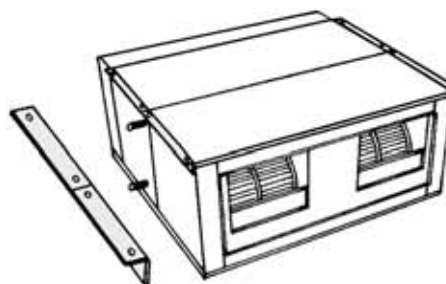

Optional extras

- For Ocean size 1 and size 2 only.
- ON-OFF switch and 3 speed switch.
- Without thermostatic control.

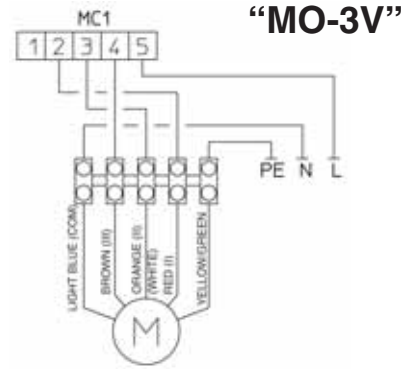
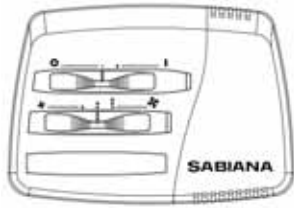

- For Ocean size 1 and size 2 only.
- ON-OFF switch.
- 3 speed switch.
- Summer/Winter switch.
- Electronic room thermostat for fan or valves control (ON-OFF).
- It allows to control the low temperature cut-out thermostat (TME).
- It allows to control the chilled water valve (ON-OFF) and the heating electric battery only in case that the coil is not feeded with warm water in winter and using support relé.

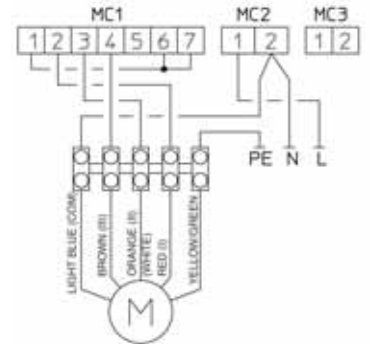
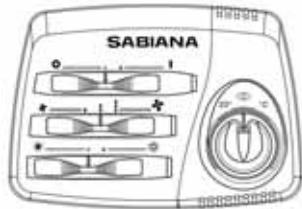

Recessed manual speed control switch

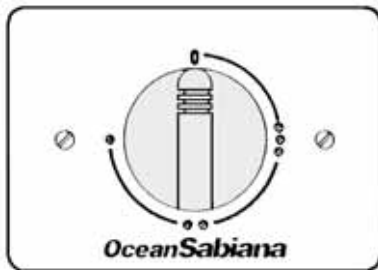

Manual speed control with thermostat and summer/winter switch

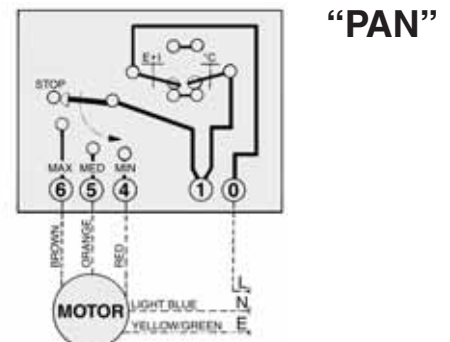
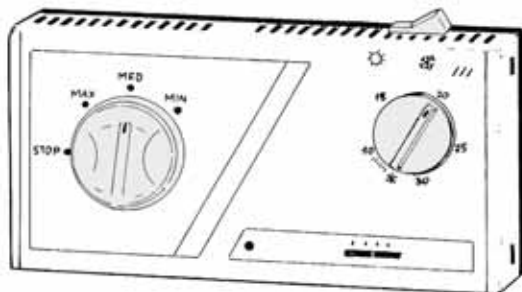

Electronic variable speed drive

