



**SABIANA**

ENVIRONMENTAL COMFORT



# Janus 05 Air Conditioner

The Sabiana *Janus 05 air conditioner* provides a simple solution to centralised air conditioning systems offering great flexibility in installation and project design, minimum space required for the units not taking up valuable floor space, and low user running cost. *Janus 05* can be matched to the Sabiana Krio range of indoor and outdoor chillers and heat pumps.

The *Janus 05 air conditioners* are produced in 4 sizes, each available with a 3-row or a 4-row battery, heat outputs from 16 to 104 kW and cooling capacities from 5 to 28 kW.



## Main components:

- **CASING**  
Made from galvanized prepainted steel finished in dove grey, and assembled from three component parts.
- **HEAT EXCHANGER**  
The heat exchanger is manufactured from the highest quality copper tube. The fins are pressed from aluminium sheet, bonded onto the tubes facilitating the maximum transfer contact available.
- **FAN ASSEMBLY**  
It is made up of three components: the fan, the motor and the finger proof guard, which also acts as the main support.
- **ELECTRIC MOTOR**  
The standard motor fitted is a hermetically sealed motor which is maintenance free. The motor is 2 speeds, 3 phase, single voltage, 400 V 50 Hz, with klixon thermal protection.
- **CONDENSATE TRAY**  
The insulated condensate tray is fitted inside the casing under the battery.



## Janus 05 Technical Characteristics

### HEATING EMISSION

MODEL		46 F 23		46 F 24		46 F 43		46 F 44		68 F 63		68 F 64		68 F 93		68 F 94	
Mounting height	m	2.5 ÷ 4				3 ÷ 4.5				3 ÷ 5				3.5 ÷ 5.5			
Speed	r.p.m.	1350	950	1350	950	1350	950	1350	950	900	700	900	700	900	700	900	700
Air flow	m <sup>3</sup> /h	2200	1500	2000	1400	3800	2500	3400	2150	4350	3600	4000	3150	8250	6250	7800	5950
Throw	m	11	7.5	10	7	16	12	14	10	18	14	17	13	26	20	24	18
Noise level at 5 m.	dB (A)	59	51	59	51	64	54	64	54	60	52	60	52	66	60	66	60
W.T. 45/40°C Δt 5°C	kW	8.3	6.6	9.5	7.5	14.1	11.0	16.2	12.1	19.0	16.6	21.4	18.2	36.5	31.0	42.3	33.6
E.A.T. +15°C	L.A.T. °C	27.1	29.0	30.4	32.3	26.9	29.0	30.3	32.7	28.7	29.9	32.2	33.6	29.2	30.6	32.3	34.2
W.T. 85/75°C Δt 10°C	kW	20.4	16.1	23.3	18.5	34.5	26.9	39.77	29.6	46.3	40.3	52.0	44.0	89.5	75.9	103.6	82.0
E.A.T. +15°C	L.A.T. °C	44.8	49.5	52.8	57.5	44.2	49.2	52.3	58.2	48.4	51.2	56.9	60.1	49.8	53.2	57.4	61.9
W.T. 90/70°C Δt 20°C	kW	19.5	15.5	22.5	18.0	33.2	26.0	38.6	29.0	45.2	39.5	51.1	43.5	86.6	73.8	100.9	80.4
E.A.T. +15°C	L.A.T. °C	43.5	48.2	51.5	56.3	43.1	48.2	51.3	57.3	47.6	50.4	56.2	59.6	48.7	52.1	56.3	61.0

## Janus 05 Technical Characteristics

### COOLING EMISSION

MODEL		46 F 23		46 F 24		46 F 43		46 F 44		68 F 63		68 F 64		68 F 93		68 F 94	
Mounting height	m	2.5 ÷ 4				3 ÷ 4.5				3 ÷ 5				3.5 ÷ 5.5			
Speed	r.p.m.	950		950		950		950		700		700		700		700	
Air flow	m <sup>3</sup> /h	1500		1400		2500		2150		3600		3150		6250		5950	
Throw	m	7.5		7		12		10		14		13		20		18	
Noise level at 5 m.	dB (A)	51		51		54		54		52		52		60		60	
W.T. 7/12°C Δt 5°C	kW Total	5.3		6.3		9.1		10.6		13.8		15.9		25.0		28.2	
	kW Sensible	3.6		4.2		6.2		6.9		9.2		10.2		16.9		18.4	
E.A.T. +28°C R.H. 55%	L.A.T. °C	19.9		17.9		19.8		17.5		19.4		17.2		19.1		17.0	
W.T. 11/15°C Δt 4°C	kW Total	3.7		4.4		6.4		7.5		9.8		11.3		17.6		20.0	
	kW Sensible	3.1		3.5		5.2		5.8		7.7		8.55		14.2		15.4	
E.A.T. +28°C R.H. 55%	L.A.T. °C	21.1		19.6		21.1		19.2		20.8		19.0		20.5		18.8	
W.T. 9/14°C Δt 5°C	kW Total	4.2		5.0		7.3		8.6		11.3		13.0		20.1		22.8	
	kW Sensible	3.3		3.7		5.5		6.1		8.2		9.1		15.1		16.4	
E.A.T. +28°C R.H. 55%	L.A.T. °C	20.7		19.0		20.7		18.7		20.3		18.3		20.1		18.2	



## Janus 05 identification code

Reference: 46F43

<b>46</b>	<b>F</b>	<b>4</b>	<b>3</b>
MOTOR 4-6 POLE (1350-900 r.p.m.)	RANGE JANUS	SIZE 4	ROWS 3

## Dimensions, weight and water content

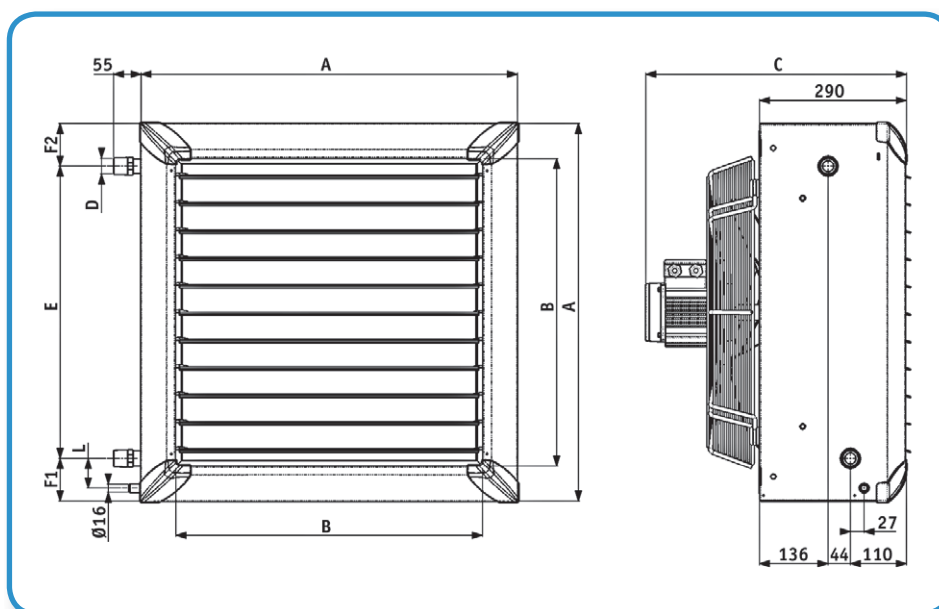

MODEL	A	B	C	D	E	F1	F2	l	WEIGHT (kg)	WATER CONTENT (litres)
<b>46 F 23/24</b>	526	390	475	1"	376	78	71	58	23	1,9
<b>46 F 43/44</b>	634	498	500	1"	476	76	83	58	30	2,9
<b>68 F 63/64</b>	742	606	525	1"	576	83	83	58	40	4,3
<b>68 F 93/94</b>	1010	874	650	1 1/2"	818	90	100	67	75	8,4



## Accessories

### **AMP**

Wall bracket.

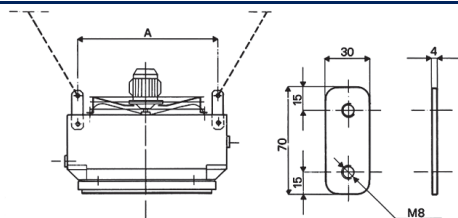
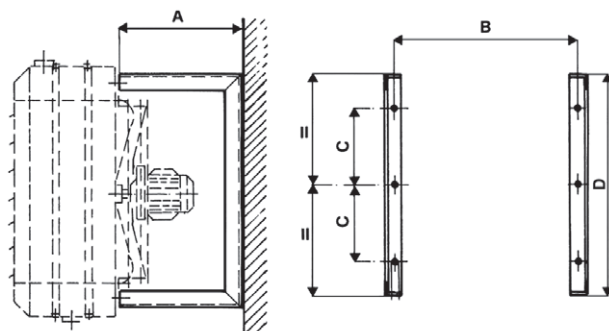

### **AS**

Suspension plate for ceiling installation.

### **4 way diffuser AD**

To be used when discharging downflow to create a 4 way discharge pattern. For normal heights of installation.

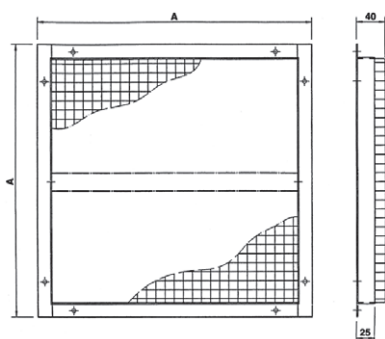
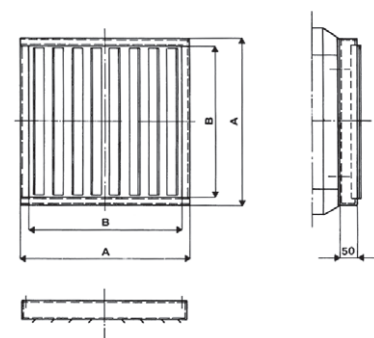

### **APP**

Ball protection grid.

## Controls

### **BS 3-ST**

Manual three-position switch with thermostat.

