

**Contents**

	<b>Page</b>
Introduction.....	5
Superheat.....	5
Subcooling.....	5
External pressure equalization.....	6
Charges.....	6
Universal charge.....	6
MOP charge.....	6
MOP ballast charge.....	7
Thermostatic expansion valve selection.....	7
Identification.....	7
Installation.....	8
Setting.....	9
Orifice assembly replacement.....	10
Danfoss product range.....	11



**Introduction**

A thermostatic expansion valve is built up around a thermostatic element (1) separated from the valve body by a diaphragm.

A capillary tube connects the element to a bulb (2) and a valve body with valve seat (3) and a spring (4).

**A thermostatic expansion valve works like this:**

The function of a thermostatic expansion valve is determined by three fundamental pressures:

- P1: Bulb pressure which acts on the upper surface of the diaphragm, in the valve opening direction.
- P2: Evaporating pressure which acts on the underside of the diaphragm, in the valve closing direction.
- P3: Spring pressure which also acts on the underside of the diaphragm, in the valve closing direction.

When the expansion valve regulates, balance is created between bulb pressure on one side of the diaphragm and evaporating pressure plus spring force on the other side.

The spring is used to set superheat.

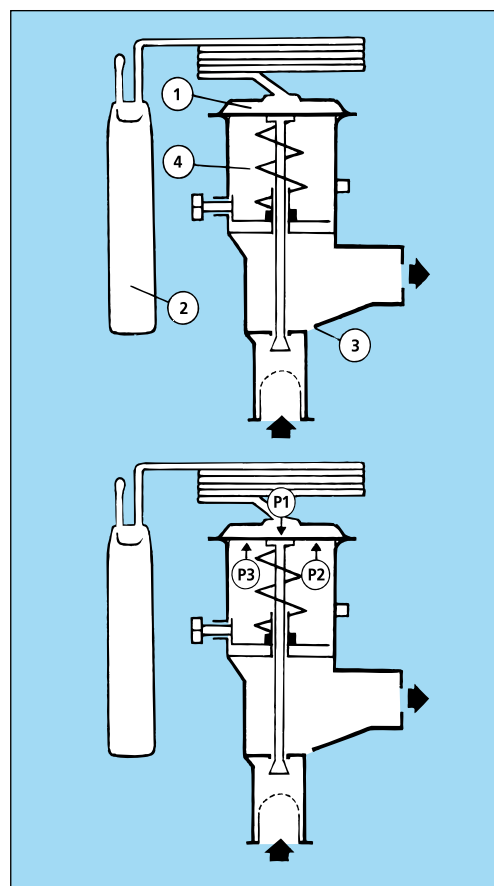

Ad0-0001

**Superheat**

Superheat is measured at the point where the bulb is located on the suction line and is the difference between the temperature at the bulb and the evaporating pressure/evaporating temperature at the same point.

Superheat is measured in Kelvin (K) and is used as a signal to regulate liquid injection through the expansion valve.

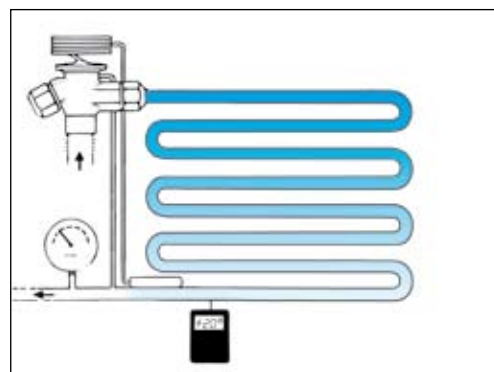

Ad0-0012

**Subcooling**

Subcooling is defined as the difference between condensing pressure/temperature and liquid temperature at the expansion valve inlet.

Subcooling is measured in Kelvin (K). Subcooling of the refrigerant is necessary to avoid vapour bubbles in the refrigerant ahead of the expansion valve.

Vapour bubbles in the refrigerant reduce capacity in the expansion valve and thereby reduce liquid supply to the evaporator.

Subcooling of 4-5K is adequate in most cases.

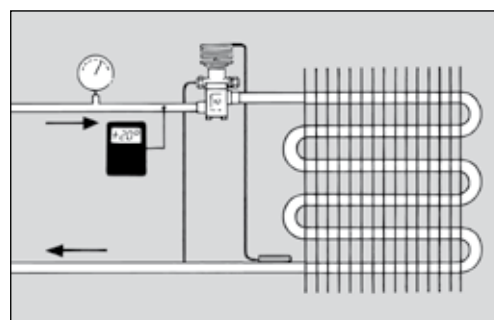

Ad0-0015

**External pressure equalization**

Expansion valves with external pressure equalization must always be used if liquid distributors are installed.

Typically, the use of distributors gives a pressure drop of 1 bar across distributor and distribution tubes.

Expansion valves with external pressure equalization should always be used in refrigeration systems with heavy evaporators or plate exchangers, where normally the pressure drop will be greater than pressure corresponding to 2K.

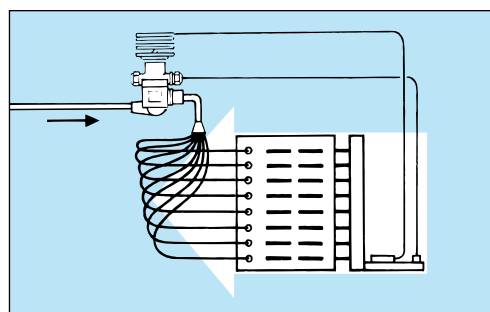

Ad0-0016

**Charges**

Thermostatic expansion valves can contain one of three different types of charge:

1. Universal charge
2. MOP charge
3. MOP charge with ballast, standard for Danfoss expansion valves with MOP.

*Universal charge*

Expansion valves with **Universal charge** are used in most refrigeration systems where there is no pressure limitation requirement and where the bulb can be located warmer than the element or at high evaporating temperature/evaporating pressure.

**Universal charge** means that there is liquid charge in the bulb. The amount of charge is so large that charge remains in the bulb irrespective of whether the element is colder or warmer than the bulb.

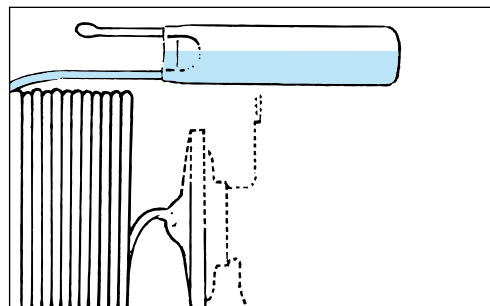

Ad0-0017

*MOP charge*

Expansion valves with **MOP charge** are typically used on factory-made units where suction pressure limitation on starting is required, e.g. in the transport sector and in air conditioning systems.

All expansion valves with MOP have a very small charge in the bulb.

This means that the valve or the element must be located warmer than the bulb. If it is not, charge can migrate from the bulb to the element and prevent the expansion valve from functioning.

**MOP charge** means limited liquid charge in the bulb.

“MOP” stands for Maximum Operating Pressure and is the highest suction pressure/ evaporating pressure permissible in the evaporator/suction line.

The charge will have evaporated when the temperature reaches the MOP point. Gradually, as the suction pressure rises, the expansion valve begins to close at approx. 0.3/0.4 bar below the MOP point. It becomes completely closed when the suction pressure is the same as the MOP point.

MOP is often called “Motor Overload Protection”.

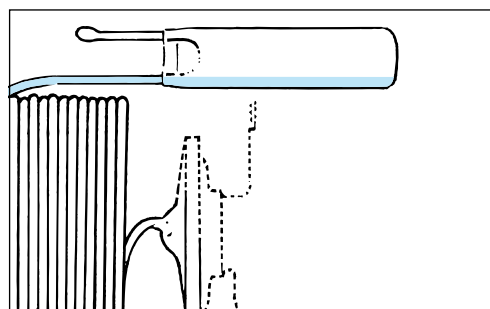

Ad0-0018

**MOP ballast charge**

Expansion valves with **MOP ballast charges** are used mainly in refrigeration systems with "high-dynamic" evaporators, e.g. in air conditioning systems and plate heat exchangers with high heat transfer.

With MOP ballast charge, up to 2 - 4 K less superheat can be obtained than with other types of charge.

The bulb in a thermostatic expansion valve contains a material of high porosity and large surface area in relation to weight.

MOP charge with ballast has a damping effect on expansion valve regulation.

The valve opens slowly as bulb temperature rises and closes quickly as bulb temperature falls.

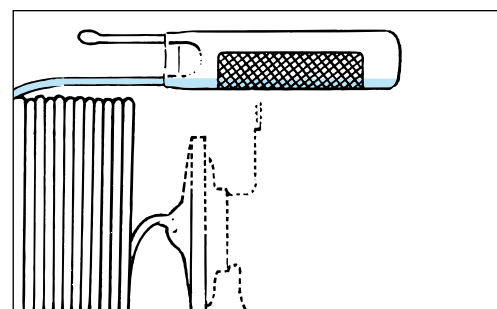

Ad0-0021

**Thermostatic expansion valve selection**

The thermostatic expansion valve can be selected when the following are known:

- Refrigerant
- Subcooling
- Evaporator capacity
- Pressure drop across valve
- Evaporating pressure
- Internal or external pressure equalization
- Condensing pressure

**Identification**

The thermostatic element is fitted with a laser engraving on top of the diaphragm.

The code refers to the refrigerant for which the valve is designed:

- L = R410A
- N = R134a
- S = R404A/ R507
- X = R22
- Z = R407C

This engraving gives valve type (with code number), evaporating temperature range, MOP point, refrigerant, and max. working pressure, PS/MWP.

With TE 20 and TE 55 the rated capacity is stamped on a band label fastened to the valve.

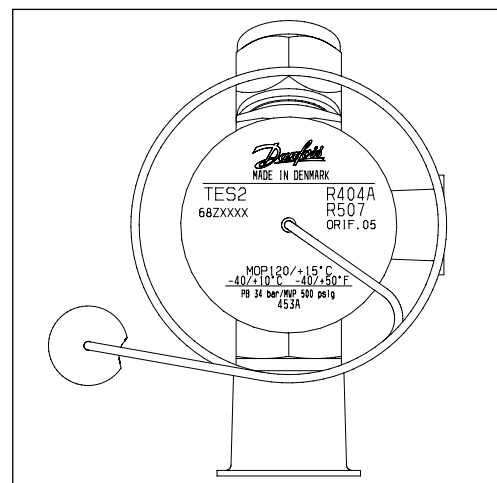

Ad0-0019

The orifice assembly for T2 and TE2 is marked with the orifice size (e.g. 06) and week stamp + last number in the year (e.g. 279). The orifice assembly number is also given on the lid of its plastic container.

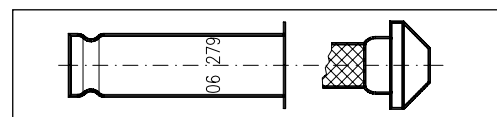

Ad0-0023

On TE 5 and TE 12 the upper stamp (TE 12) indicates for which valve type the orifice can be used. The lower stamp (01) is the orifice size.

On TE 20 and TE 55 the lower stamp (50/35 TR N/B) indicates the rated capacity in the two evaporating temperature ranges N and B, and the refrigerant. (50/35 TR = 175 kW in range N and 123 kW in range B).

The upper stamp (TEX 55) refers to the valve type for which the assembly can be used.

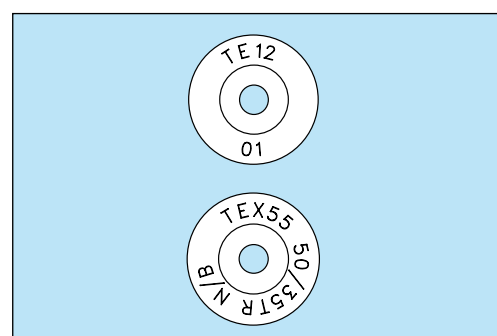

Ad0-0020

**Installation**

The expansion valve must be installed in the liquid line, ahead of the evaporator, with its bulb fastened to the suction line as close to the evaporator as possible.

If there is external pressure equalization, the equalizing line must be connected to the suction line immediately after the bulb.

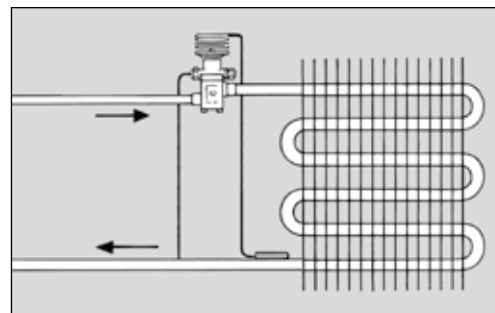

Ad0-0002

The bulb is best mounted on a horizontal suction line tube and in a position corresponding to between 1 o'clock and 4 o'clock.

Location depends on the outside diameter of the tube.

**Note:**

The bulb must never be located at the bottom of the suction line due to the possibility of oil laying in the bottom of the pipe causing false signals.

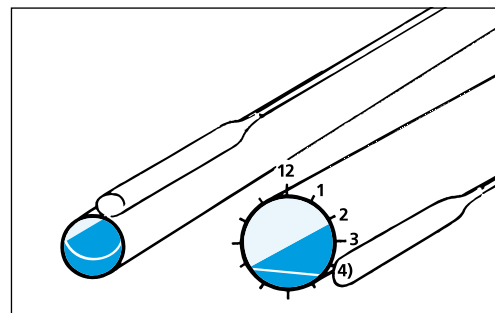

Ad0-0003

The bulb must be able to sense the temperature of the superheated suction vapour and must therefore not be located in a position that will expose it to extraneous heat/cold.

If the bulb is exposed to a warm air current, insulation of the bulb is recommended.

The Danfoss bulb strap allows a tight and secure fitting of the bulb to the tube, thereby securing that the bulb has ultimate thermal contact to the suction tube. The TORX design of the screw makes it easy for the fitter to transfer the torque from the tool to the screw without having to press the tool into the screw slot. Furthermore, with the TORX slot design, there is no risk of damaging the screw slot.

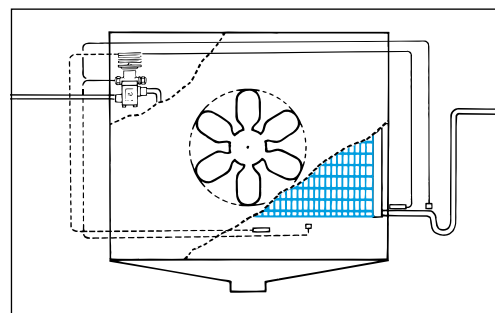

Ad0-0004

The bulb must not be installed after a heat exchanger because in this position it will give false signals to the expansion valve.

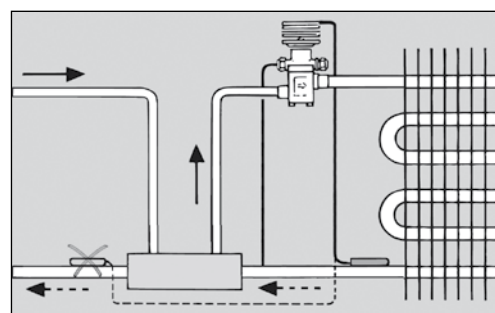

Ad0-0005

The bulb must not be installed close to components of large mass as this also will give rise to false signals to the expansion valve

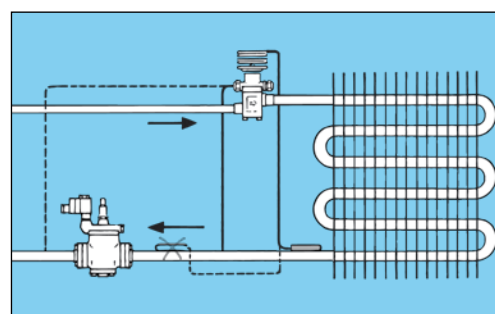

Ad0-0006

**Installation (cont.)**

As previously mentioned, the bulb must be installed to the horizontal part of the suction line immediately after the evaporator. It must not be installed to a collection tube or a riser after an oil pocket.

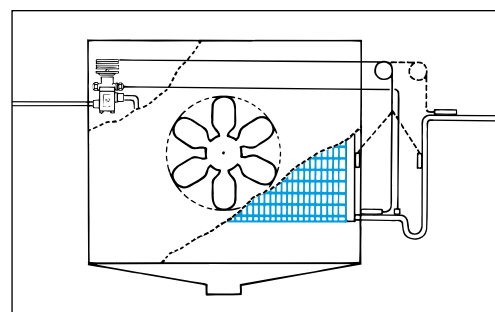

Ad0-0007

The expansion valve bulb must always be installed ahead of any liquid lock.

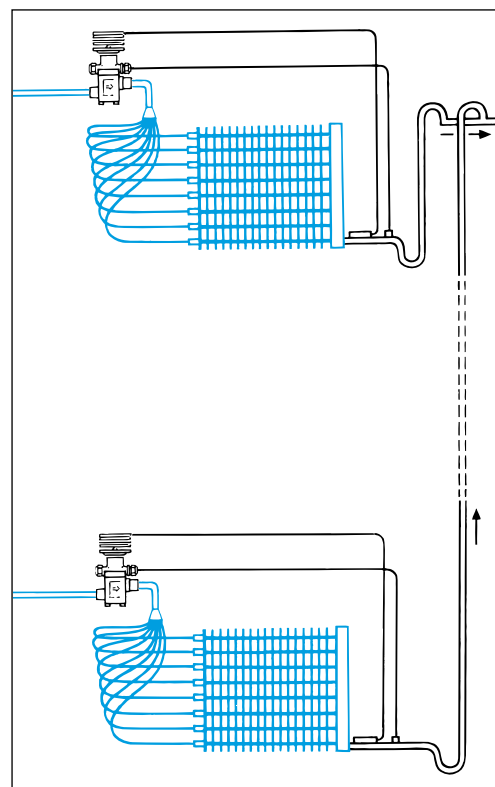

Ad0-0008

**Setting**

The expansion valve is supplied with a factory setting suitable for most applications.

If necessary, readjustment can be made using the setting spindle on the valve.

Turning the spindle clockwise increases the expansion valve superheat and turning it counterclockwise reduces it.

For T /TE 2, one turn of the spindle produces a change of approx. 4K in the superheat at 0°C evaporating temperature.

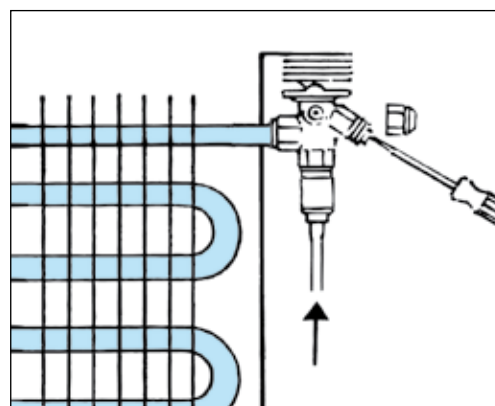

Ad0-0009

**Setting (cont.)**

For TE 5 and following sizes, one turn of the spindle produces a change of approx. 0.5K in the superheat at 0°C evaporating temperature.

For TUA and TUB, one turn of the spindle produces a change of approx. 3K in the superheat at 0°C evaporating temperature.

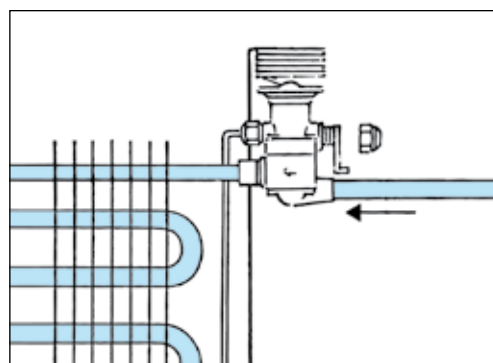

Ad0-0010

Hunting in the evaporator can be eliminated by the following procedure:  
 Increase the superheat by turning the expansion valve setting spindle well to the right (clockwise) so that hunting stops. Then turn the setting spindle in counter-clockwise steps so that hunting again occurs.

From this position, turn the spindle about once clockwise (but only 1/4 turn for T/TE 2 valves).

On this setting the refrigeration system will not hunt and the evaporator is fully utilized. A variation of 1 K in superheat is not regarded as hunting.

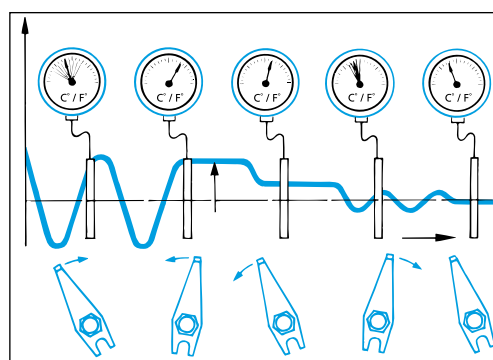

Ad0-0011

If the superheat in the evaporator is too high, the reason might be an inadequate supply of liquid refrigerant.

The superheat can be reduced by turning the expansion valve setting spindle counterclockwise in steps until hunting is observed.

From this setting, the spindle must be turned about once clockwise (but only 1/4 turn for T/TE 2). This setting fully utilizes the evaporator. A variation of 1 K in superheat is not regarded as hunting.

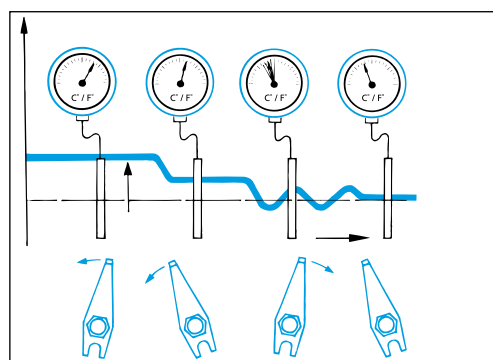

Ad0-0013

**Orifice assembly replacement**

If the evaporator continues to hunt, regardless of the superheat setting, the valve capacity might be too high and the orifice assembly, or the valve, needs replacing with a smaller one.

If the evaporator superheat is too high the valve capacity is too low and the orifice assembly must be replaced with a larger one.

TE, T2, TUA, TCAE valves are supplied with an interchangeable orifice.

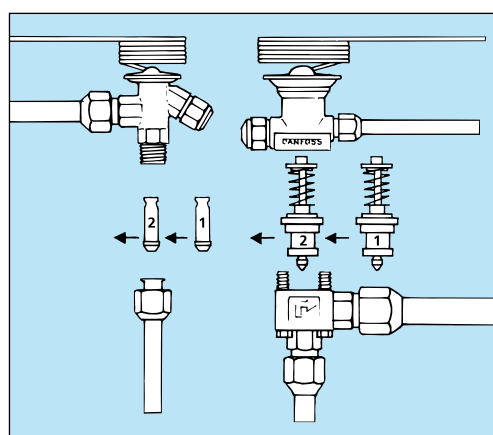

Ad0-0014

## Fitters notes

## Thermostatic expansion valves

**Danfoss product range  
Thermostatic expansion  
valves**

Danfoss offers a comprehensive range of thermostatic expansion valves with capacities from 0.4 to 1083 kW (R134a).

**T/TE 2** valves have a brass housing and flare/flare or solder/flare connections.  
*Rated capacity: 0.4 - 10.5 kW (R134a).*

**TUA, TUB, TUC** valves have a stainless steel housing and stainless steel/copper bimetal solder connections.

*Rated capacity: 0.5 - 12 kW (R134a).*

The valves can be supplied with or without external pressure equalization.

- TUA has an interchangeable orifice assembly and adjustable superheat.
- TUB has a fixed orifice and adjustable superheat.
- TUC has a fixed orifice and factory set superheat.

TUB and TUC are primarily for OEM customers. All TUB and TUC valves can be replaced by TUA valves.

**TCAE, TCBE, TCCE** valves have a stainless steel housing and stainless steel/copper bimetal solder connections.

*Rated capacity: 12 - 18 kW (R134a).*

The valves are designed as the TU valves but with a higher capacity.

The valves are supplied with external pressure equalization.

**TRE** valves have a brass housing and stainless steel/copper bimetal connections.

*Rated capacity: 18 - 196 kW (R134a).*

The valves are supplied with a fixed orifice and adjustable superheat.

**TDE** valves have a brass housing and copper solder connections.

*Rated capacity: 10.5 - 140 kW (R407C)*

The valves are supplied with a fixed orifice and adjustable superheat.

**TE 5 - TE 55** valves have a brass housing.

The valves are supplied as a part programme consisting of valve housing, orifice and thermostatic element.

The valve housing is available in a straightway or angleway version with solder, flare and flange connections.

*Rated capacity: 12.9 - 220 kW (R134a).*

The valves are supplied with external pressure equalization.

**PHT 85 - 300** valves are supplied as a part programme consisting of valve housing, flanges, orifice and thermostatic element.

*Rated capacity: 55 - 1083 kW (R134a).*

For further information consult the internet or the catalogue material.

